



RST GLOBAL NETWORK

Head quarter
Dah ken Ind. Co., Ltd.

Tel: +886-2-85212351
Fax: +886-2-85216159
Email: rst@rst.com.tw
Http://www.rst.com.tw

USA

RST USA Service & Distributor
Tel: +1-(661)-360-9946
Email: sales@rstuspensionusa.com

Europe

RST Europe Office
Tel: +49-711-2588221
Fax: +49-711-2588402
Email: info@rst-europe.eu

China

Suzhoun Dawei Precision Co.,Ltd
Tel: +86-512-86160698
Fax: +86-512-86160100
Email: services@rst-topway.cn

RST PRODUCT SPEC 2013

PRODUCT SPEC

2 0 1 3

From 1972, RST bring you the finest suspension technology to change your cycling style.

DH/FR/AM
XC/ATB
XC/650B
DIRT JUMP
TREKKING/CROSS

RST
40th Anniversary

Contents

15

DH/FR/AM

EVOLUTION	03
SYMBOL	05
PRODUCT OVERVIEW	06
NEW COLLECTION	
SEATPOST	07
SS-HF7	08
SS-HF6	08
HYDRO-R	09
HYDRO-6	10
HYDRO-7	10
AFTER MARKEE	11

R1	17
STORM	18
TITAN15	19
TITAN	20

21

XC/ATB

CHAMP 32	23
CHAMP 30-15	24
CHAMP 29-15	25
CHAMP 29	26
FIRST 32	27
FIRST 30-15	28
FIRST 30 PLATINUM	29
FIRST 30/FIRST 24	30
FIRST 29-15	31
FIRST 29	32
AERIAL 32	33
AERIAL 30	34
AERIAL 29	35
OMEGA 29/OMEGA	36
BLAZE 29 / BLAZE	37
GILA / CAPA	38

39

XC/650B

BLAZE 650B 40

41

DIRT JUMP

SPACE/DIRT 42

43

CROSS TREKKING

VOGUE	45
VITA	46
NEON PLS / SOFI PLS	47
PLS INFO	48
NEON / SOFI	49
SINGLE SHOCK-M SERIES	
SS-M7 / M7T	50
SS-M6 / M6T	50
SINGLE SHOCK-A SERIES	
SS-A7 / A7T	51
SS-A6 / A6T	51
SS-A4 / A4T	51
SS-A2	51
RIGID FORKS	
RF-M7, RF-M6	52
ELEMENT	53

DIMENTION	54
DETAILS	55
GLOBAL OVERVIEW	65
GLOBAL DISTRIBUTOR	66

EVOLUTION

FEATURES & TECHNOLOGY

New lightweight design – the OCR cartridge system

In order to reduce the weight of our forks without sacrificing the performance, RST will present the new system CHAMP series for Dah Ken 40th anniversary.

The benefit of this system is the use of a cartridge system, easy to maintain, reducing the weight and keeping the same high performance level of the open bath RST forks.

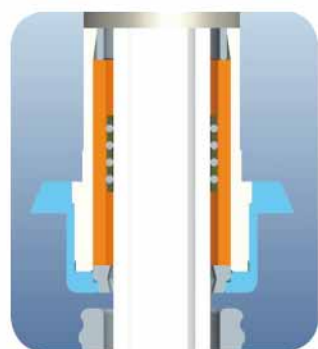

New system of 2nd single shock - needle bearing system

The 2nd generation single shock fork is using needle bearing system to provide rider a real comfortable riding experience and elegant way to combine the optic of a non-suspended bike with an energy saving suspension function.

Individual OCR platform

The OCR platform system is meant to increase the pedal efficiency while riding the bike. In the RST MY 2012 range, this function has always been combined with the Air preload adjustment. But for the 2013 RST product lineup, the function "OCR platform" can be upgraded at all Air Spring forks of the AM & FR category. The shape of red adjuster has been modified so the rider can easily recognize the status of the Platform compression while riding.

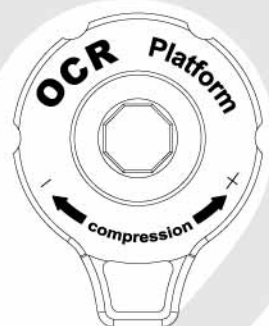

New Air system - Air cartridge

Upgrade your fork from a coil spring into an air spring system. Riders with limited budget will have the opportunity to upgrade their coilspring fork with RST new Air spring cartridgesystem –they will not have to purchase an entire new air spring fork. This system will also be available on the following MY13 fork models: AERIAL 32, AREIAL 30, AERIAL 29.



PLS - Post Lighting System

RST PLS stands for the front lamp bracket integration into the fork arch from the rear side fixed by two bolts. This will keep the clean looking of the fork and in case no light is needed, a plastic cover will be available to cover the open slot.



One piece type Hydro forming technology

The Hydro forming technology is already widely used in the world, however, the use of one pc type hydro forming process gives RST the chance to create a lightweight design while keeping the strength on a very high end level. In the RST MY 2013 lineup, we are using this technology at the city & trekking range (700C and 26") as well as for road bike forks.

Height adjustable Seat Post

RST is highlighting the brand new height adjustable seat post for MY 2013 – taking a look at the market this product is a must-have at every AM and FR bike. Even while riding XC you will feel the benefit of increased control – just adjust the seat post height by a remote control lever or a lever next to the saddle. The RST hydraulic technology used in this seat post will bring you to the next level!



SYMBOL



Category	Symbol	Model/Spec	Description
Wheel		700c	Available for 700c wheel
		29	Available for 29' wheel
		26	Available for 26' wheel
		24	Available for 24' wheel
		20	Available for 20' wheel
Material		MAG	Magnesium casting
		ALU	Aluminum casting
Brake		V-brake	V-brake boss available
		Post disc (max)	Post disc mount available with recommended disc diameter
		IS disc (max)	IS disc mount available with recommended disc diameter
		Roller	Roller brake anchor boss available (option)
Accessory		Carrier	Front carrier mount available (option)
		Dynamo	Dynamo mount available
		PLS	Post Lighting System
		Cable routing	Cable routing available for hub dynamo cable
		OCR Platform	System
System		OCR	Equipped with OCR system
		OCR2	Equipped with OCR2 system
		RA	RA option available
		AIR	Equipped with AIR system
		T	Spring pre-load adjustment available
		C	Spring only, Non adjustable
		SRL	SRL option available
		RL	RL option available
		TNL	TNL option available
		ML	ML option available
	TQC	Equipped with TQC dropout	
	15 QR	Equipped with 15mm QR axle.	
	1.5" CROWN	1.5" Crown option available	

PRODUCT OVERVIEW



	Down Hill	Free Ride	All Mountain	XC	650B	29'er	Dirt Jump	Leisure Sport	Junior	Cross	Trekking	Hydro Forming	Seat Post	Rear Shock	
Taiwan-Made Product		R1		CHAMP32		CHAMP29-15									
	\$\$\$\$\$		STORM Platform	CHAMP30-15		CHAMP29									
			TITAN 15 Platform	FIRST 30 Platinum											
			TITAN Platform												
	\$\$\$\$		STORM Air	FIRST 32 Air		FIRST 29-15 AIR	SPACE		FIRST 24	VOGUE	Single Shock HF series			Seat post	ELEMENT
			TITAN 15 Air	FIRST 30-15 Air		FIRST 29 Air									
China-Made Product	\$\$\$			AERIAL 32		AERIAL 29						Single Shock M series			
				AERIAL 30								Single Shock A series	Hydro-7	Hydro-6	
	\$\$			OMEGA		OMEGA 29					VITA				
				BLAZE	BLAZE 650B	BLAZE 29	DIRT			NEON PLS	SOFI PLS				
				GILA				CAPA 26	CAPA 24/20	NEON	SOFI				

COLOR OPTIONS



	DK-8011 SHINY BLACK (YS-728)
	DK-8010 MATT BLACK (YS-727)
	DK-0011 GLOSS WHITE (YS-701)
	DK-0012 PEARL WHITE (YS-775)
	DK-9032 GLOSS SILVER (YS-7605)

STEERER WEIGHT



Steerer Tube	Length	Weight	
Aluminum 7050	28.6mm	260mm	178g
Aluminum 7050	1.5"	260mm	188g
Aluminum 7050	1.5" Taper	260mm	170g
Hi-ten	28.6mm	260mm	333.5g
Hi-ten	25.4mm	260mm	283g

SEATPOST

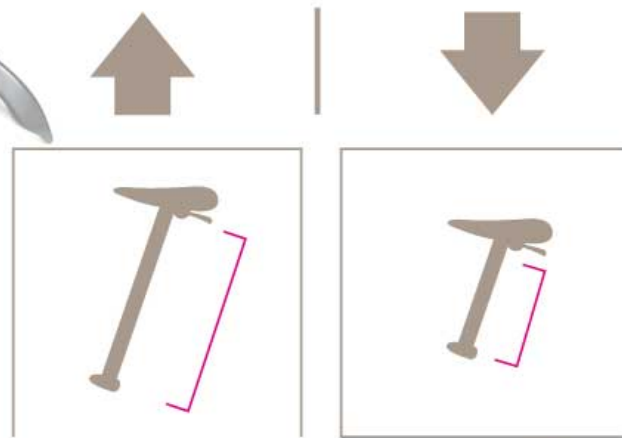

JOYSTICK



Model	Joystick	Joystick-R
Function	Height adjustable post	Height adjustable post
Travel	100, 125 mm	100, 125 mm
Features	Lever operated	Remote operated
Diameter	30.9/31.6 mm	30.9/31.6 mm
Length	385-410 mm	385-410 mm
Weight	480g	530g



↑
MAXIMUM RISERT
Max. torque 8 Nm
80kg/cm (180lb)
ø 30.9

SINGLE SHOCK



SS-HF6

SS-HF7

SS-HF7 / SS-HF6



Model	SS-HF7	SS-HF6
Wheel size	700C	26"
Travel	35mm	35mm
Feature	Alu. blade	Alu. blade
Steerer	28.6mm A-7050 Aluminum	28.6mm A-7050 Aluminum
Lower	Aluminum 9mm Open Dropout	Aluminum 9mm Open Dropout
Brake Type	Disc & V-brake	Disc & V-brake
Weight (kgs) (w/steerer at 200mm)	1.15	1.10





HYDRO-R



Model	HYDRO-R
Wheel Size	700C
Feature	Alu. blade
Steerer	28.6mm A-7050 Aluminum
Lower	Aluminum, 9mm Open Dropout
Brake Type	Caliper-brake
Weight (kgs) (W/200mm steerer)	0.55



0.55
KG

HYDRO FORMING

HYDRO-FORMING



HYDRO-6



HYDRO-7

0.65
KG

HYDRO-6 HYDRO-7



Model	HYDRO-6	HYDRO-7
Wheel Size	26"	700C
Feature	Alu. blade	
Steerer	28.6mm A-7050 Aluminum	28.6mm A-7050 Aluminum
Lower	Aluminum, 9mm Open Dropout	
Brake Type	Option (V-brake or Disc brake)	
Weight(kgs) (W/200mm steerer)	0.60	0.65

ACCESSORIES & TOOLS



The Air Cartridge Upgrade allows a fork with a coil spring system to be converted to an air spring system in a simple, easy to install package. This modification gives the rider a much greater ability to fine tune the fork for the exact ride that he desires. It also lightens up the bike as the steel coil spring is eliminated. The Air Cartridge Upgrade Kit is currently available for a limited number of steel legged forks.

Fitments Available For

30mm Stanchion Forks W/ QR or 15TA	All OMEGA 26"	All BLAZE 26"
32mm Stanchion Forks W/ QR or 15TA	All OMEGA 29r	

Air Cartridge Upgrade Kit

The Wireless system brings the benefit of a remote lock, free of cables and the need to maintain them, unlimited options in mounting the control unit and a cleaner look at the bike. The Wireless Lock-out Upgrade allows 4 different increasing compression settings then a fully locked-out setting at your finger tips while you ride. There is a visual display so that the rider knows at a glance what damper setting has selected.

Fitments Available For

Availability limited to all F1RST 30 Air



Wireless Lock-out Upgrade Kit



#H5GDPBARL2011

The SRL Upgrade moves the compression and lock-out control from the fork crown to a more convenient location on the handlebar. The SRL Upgrade allows 4 different increasing compression settings then a fully locked-out setting at your finger tips while you ride. The all-aluminum lever can be located on either the left or right side of the handlebar and its can be rotated in two planes both around the bar and on its mount to find the most comfortable position for the rider. The SRL Upgrade Kit can be mounted on most forks with a crown mounted lock-out control.

Fitments Available For

All F1RST forks	All TITAN Air forks	All VOGUE Air forks
All RST Forks with TnL Damping		

Smart Remote Lock-out (SRL) Upgrade Kit

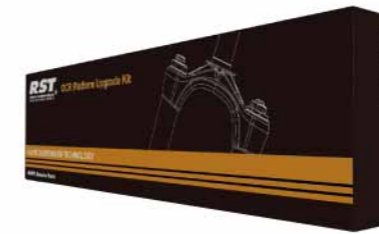

The OCR Platform allows the rider to adjust the damping rate and also independently select a pedaling platform which ranges from open to a near total lock-out for maximum on trail efficiency. All the adjustments can be quickly changed while riding. The OCR Platform Upgrade Kit is easily installed in many of the air-sprung forks.

Fitments Available For

32mm Stanchion Forks W/ both QR or 15TA	All F1RST32 Air, Air SRL All F1RST29 Air, Air SRL	All Titan Air, Air SRL
36mm Stanchion Forks	All STORM Air	All R1 Super

OCR Platform Upgrade Kit

The Air Spring Adjuster Upgrade allows the rider to adjust the air spring in 2 steps from an almost coil-like, linear spring feel through the entire travel to a progressive spring rate with more bottom-out resistance. This allows the rider to adjust the fork to precisely match the terrain and their riding style. This adjustment can be made on the fly and does not affect the riders initial sag settings. The Air Spring Adjuster Upgrade Kit is available for many of the air-sprung forks.

Fitments Available For

32mm Stanchion Forks W/ both QR or 15TA	All F1RST32 Air, Air SRL All F1RST29 Air, Air SRL	All TITAN Air, Air SRL
36mm Stanchion Forks	All STORM Air	All R1 Super

Air Spring Adjuster Upgrade Kit



ACCESSORIES & TOOLS



LUBRICATION KIT 50g

#HGACB182



Grease ■

COMPATIBLE FOR FRONT LAMP



Front Lamp Bracket for Single shock

FRONT LAMP BRACKET ■

ADAPTOR FOR QUICK RELEASE

Available for Storm, Space

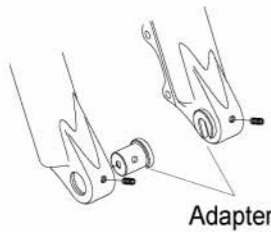

Adapter



QR ■

15mm ALUMINUM QUICK RELEASE AXLE



Available for Titan 15, CHAMP 30-15, CHAMP 29-15
F1RST 30-15, F1RST 29-15

15QR ■



CABLE GUIDE FOR HUB DYNAMO



CG ■

20MM ALUMINUM THROUGH AXLE

Available for R1, Storm, Space



20mm
Aluminum Thruaxle

TA ■

BAGPIPE AIR-SYSTEM PUMP

BAGPIPE for RST Air-System

PFGP - 2200 - 200



RST SPECIAL WRENCH

for disassemble Pre-load adjuster. (three sizes)

M5GAC616



TOOLS ■

DH/AM/FR

DOWN HILL

Extremely tough riding style for highly skilled rider who get the thrill to ride on particular steep descent. The fork for dh category needs long travel ,durability and superb hydraulic performance.

FREE RIDE

In this riding style, the riders are not only to enjoy the fun from descent riding, but aslo need to perform their jumping skill to over obstacles. The fork for freeride style needs 170mm travel at least and durable structure to dominate any tough trails, as well.

ALL MOUNTIAN

Riding for long distance ascent/ descent trail. The front fork for enduro category emphasized light weight, multi-function and long travel performance.





- **STEERER**
 - Platform 28.6mm 7050 Aluminum
 - SUPER 28.6mm 7050 Aluminum
- **ADJUSTMENT**
 - Platform Rebound, Compression, Flow gate
 - SUPER Rebound, Compression
- **SYSTEM**
 - Platform OCR Platform(R), Coil/MCU(L)
 - SUPER Oil(R), Coil/MCU(L)
- **STANCHION**
 - Platform 36mm 7050 Aluminum Hard Anodize
 - SUPER 36mm 7050 Aluminum Hard Anodize
- **CASTING**
 - Platform Magnesium, 20mm Alloy Thru-axle
 - SUPER Magnesium, 20mm Alloy Thru-axle

RONE
RAPID SUSPENSION TECHNOLOGY



R1



MODEL	Platform	SUPER
STEERER	28.6mm 7050 Aluminum	28.6mm 7050 Aluminum
CROWN PITCH	138mm-Dual	
CROWN	Aluminum Satin Black	
STANCHION	36mm 7050 Aluminum Hard Anodize	
CASTING	Magnesium, 20mm Thru-axle	
ADJUSTMENT	R, C, F	R, C
FEATURES	Rebound-adjust, Platform High/Low speed Compression	Rebound-adjust, Hydraulic Compression
SYSTEM	OCR Platform(R), Coil/MCU(L)	Oil(R), Coil/MCU(L)
TRAVEL(mm)	180 mm	
BRAKE TYPE	Disc only	
WEIGHT(kgs) (w/200mm steerer)	3.28	3.28

*R:Rebound, C:Compression, F:Flow Gate



- **STEERER**
 - Platform | Air 28.6mm 7050 Aluminum
 - SUPER 28.6mm Cr-mo steel
- **SYSTEM**
 - Platform OCR Platform(R), Air(L)
 - Air Oil(R), Air(L)
 - SUPER Oil(R), Coil/MCU(L)

- **ADJUSTMENT**
 - Platform Air, Rebound, Compression, Flow-Gate
 - Air Air, Rebound, Compression
 - SUPER Rebound
- **STANCHION**
 - Platform 36mm 7050 Aluminum Hard Anodize
 - Air 36mm 7050 Aluminum Hard Anodize
 - SUPER 36mm Cr-mo steel Ti color
- **CASTING**
 - Platform | Air Magnesium, 20mm Convertible
 - SUPER Magnesium, 20mm Convertible

STORM
RAPID SUSPENSION TECHNOLOGY

STORM



MODEL	Platform	Air	SUPER
STEERER	28.6mm 7050 Aluminum (Optional 1.5" Aluminum steerer tube)	28.6mm Cr-mo steel (Optional 1.5" Aluminum steerer tube)	28.6mm Cr-mo steel (Optional 1.5" Aluminum steerer tube)
CROWN PITCH	138mm		
CROWN	Aluminum Black Coating		
STANCHION	36mm 7050 Aluminum Hard Anodize	36mm Cr-mo steel Ti color	36mm Cr-mo steel Ti color
CASTING	Magnesium, 20mm Convertible		
ADJUSTMENT	A, R, C, F	A, R, C	R
FEATURES	Air spring, Rebound-adjust, Platform High/Low speed Compression	Air spring, Hydraulic Rebound-adjust and Compression	Hydraulic Rebound-adjust
SYSTEM	OCR Platform(R), Air(L)	Oil(R), Air(L)	Oil(R), Coil/MCU(L)
TRAVEL(mm)	140, 160, 180 mm		
BRAKE TYPE	Disc only		
WEIGHT(kgs) (w/200mm steerer)	2.50	2.50	3.00

*A:Air, R:Rebound, C:Compression, F:Flow Gate



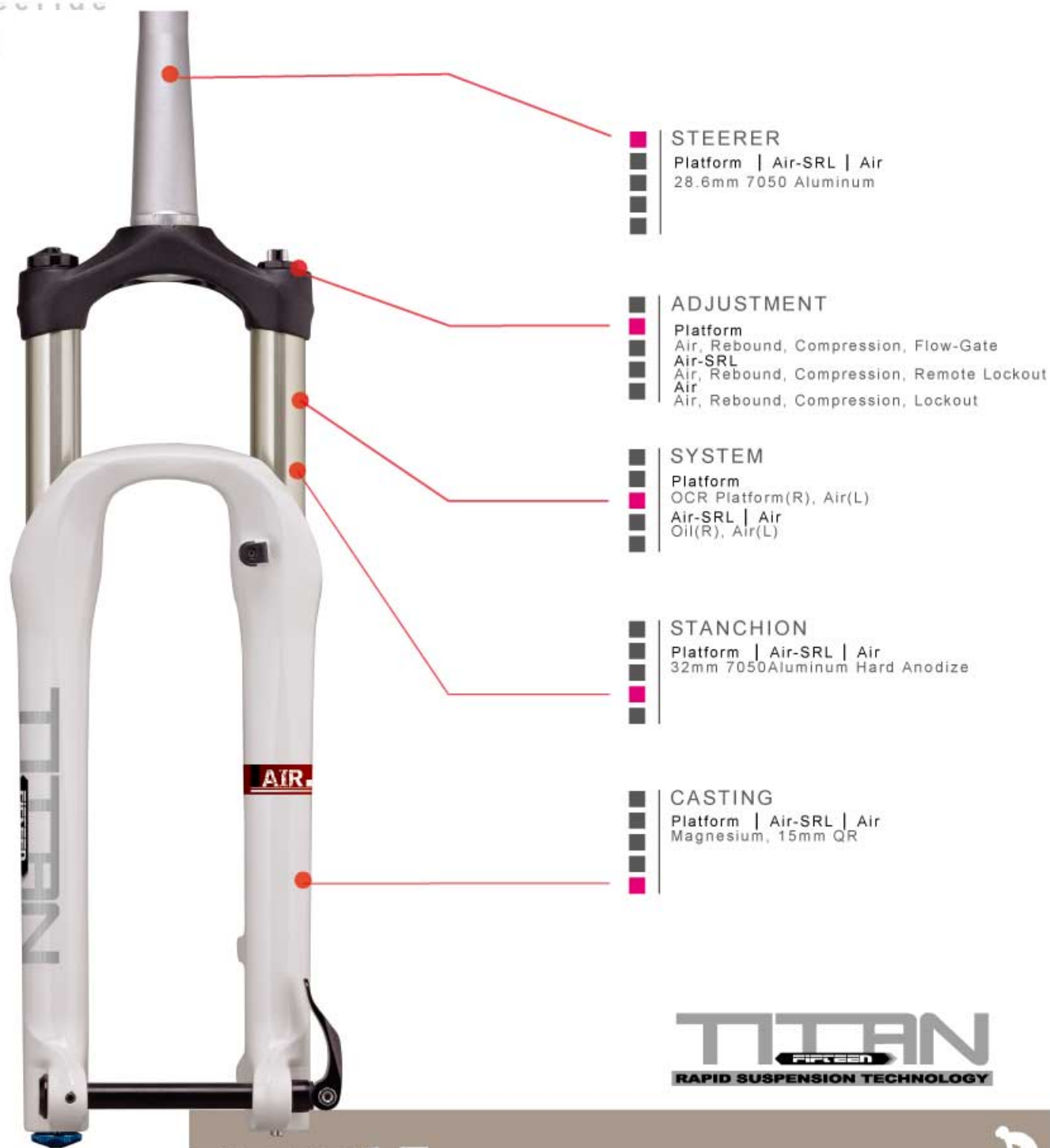

TITAN
RAPID SUSPENSION TECHNOLOGY

TITAN 15



MODEL	Platform	Air-SRL	Air
STEERER		28.6mm 7050 Aluminum (Optional 1.5" 7050 Aluminum steerer tube)	
CROWN PITCH		130mm	
CROWN		Aluminum Black Coating	
STANCHION		32mm 7050 Aluminum Hard Anodize	
CASTING		Magnesium, 15mm QR	
ADJUSTMENT	A, R, C, F	A, R, C, RL	A, R, C, L
FEATURES	Air spring, Rebound-adjust, Platform High/Low speed Compression	Air spring, Hydraulic Rebound-adjust, Remote Lock-out	Air spring, Hydraulic Rebound-adjust, Lock-out
SYSTEM	OCR Platform(R), Air(L)	Oil(R), Air(L)	
TRAVEL(mm)		140, 150 mm	
BRAKE TYPE		Disc only	
WEIGHT(kgs) (w/200mm steerer)	2.19	2.19	2.14

*A:Air, R:Rebound, C:Compression, F:Flow-Gate, RL:Remote Lock-out, L:Lock-out

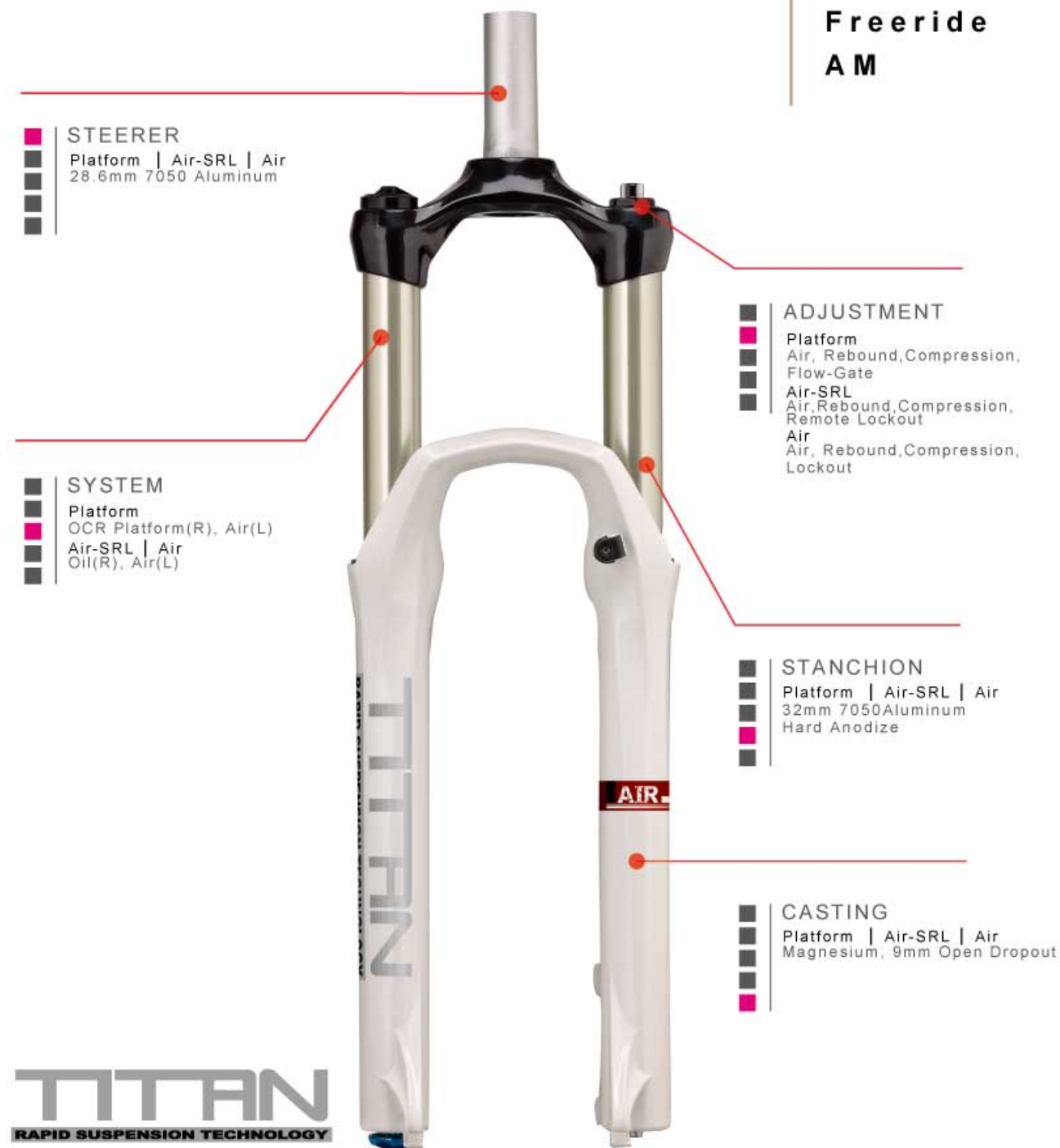

TITAN
RAPID SUSPENSION TECHNOLOGY

TITAN



MODEL	Platform	Air-SRL	Air
STEERER		28.6mm 7050 Aluminum (Optional 1.5" 7050 Aluminum steerer tube)	
CROWN PITCH		130mm	
CROWN		Aluminum Black Coating	
STANCHION		32mm 7050 Aluminum Hard Anodize	
CASTING		Magnesium 9mm Open Dropout	
ADJUSTMENT	A, R, C, F	A, R, C, RL	A, R, C, L
FEATURES	Air spring, Rebound-adjust, Platform High/Low speed Compression	Air spring, Hydraulic Rebound-adjust, Remote Lock-out	Air spring, Hydraulic Rebound-adjust, Lock-out
SYSTEM	OCR Platform(R), Air(L)	Oil(R), Air(L)	
TRAVEL(mm)		140 mm	
BRAKE TYPE		Disc or Disc & V-brake	
WEIGHT(kgs) (w/200mm steerer)	2.04	2.04	1.99

*A:Air, R:Rebound, C:Compression, F:Flow-Gate, RL:Remote Lock-out



XC/ATB

CROSS COUNTRY

For off-road riding along the mountain trails which contains some smaller obstacles and bumps. The front fork request light weight well performance and minimum 80mm travel equipped.





- **STEERER**
32-SRL | 32
28.6mm 7050 Aluminum
- **ADJUSTMENT**
32-SRL | 32
Air,Rebound,Compression,Remote Lockout
Air
Air,Rebound,Compression,Lockout
- **SYSTEM**
32-SRL | 32
OCR-Cartridge(R), Air(L)
- **STANCHION**
32-SRL | 32
32mm 7050 Aluminum Hard Anodize
- **CASTING**
32-SRL | 32
Magnesium, 9mm Open Dropout

CHAMP
RAPID SUSPENSION TECHNOLOGY

1.51 KG **CHAMP 32**

MODEL	32-SRL	32
STEERER	28.6mm 7050 Aluminum (Optional 1.5" 7050 Aluminum steerer tube)	
CROWN PITCH	130mm	
CROWN	Aluminum Black Coating	
STANCHION	32mm 7050 Aluminum Hard Anodize	
CASTING	Magnesium, 9mm Open Dropout	
ADJUSTMENT	A, R, C, RL	A, R, C, L
FEATURES	Air spring, Hydraulic Rebound-adjust, Remote Lock-out	Air spring, Hydraulic Rebound-adjust, Lock-out
SYSTEM	OCR-Cartridge(R), Air(L)	
TRAVEL(mm)	80, 100, 120 mm	
BRAKE TYPE	Disc only	
WEIGHT(kgs) (w/200mm steerer)	1.56	1.51

*A:Air, C:Compression, R:Rebound,RL:Remote Lock-out ,L:Lock-out

*Steerer Tube Options: A. 1.5"Aluminum
B. 1.5" to 1 1/8" Tapered Aluminum



- **STEERER**
30-15-SRL | 30-15
28.6mm 7050 Aluminum

- **SYSTEM**
30-15-SRL | 30-15
OCR-Cartridge(R), Air(L)

- **ADJUSTMENT**
30-15-SRL
Air,Rebound,Compression,
Remote Lockout
30-15
Air,Rebound,Compression,
Lockout

- **STANCHION**
30-15-SRL | 30-15
30mm 7050 Aluminum
Hard Anodize

- **CASTING**
30-15-SRL | 30-15
Magnesium,
15mm QR



CHAMP
RAPID SUSPENSION TECHNOLOGY

CHAMP 30-15

MODEL	30-15-SRL	30-15
STEERER	28.6mm 7050 Aluminum (Optional 1.5" 7050 Aluminum steerer tube)	
CROWN PITCH	130mm	
CROWN	Aluminum Black Coating	
STANCHION	30mm 7050 Aluminum Hard Anodize	
CASTING	Magnesium, 15mm QR	
ADJUSTMENT	A, R, C, RL	A, R, C, L
FEATURES	Air spring, Hydraulic Rebound-adjust, Remote Lock-out	Air spring, Hydraulic Rebound-adjust, Lock-out
SYSTEM	OCR-Cartridge(R), Air(L)	
TRAVEL(mm)	80, 100, 120 mm	
BRAKE TYPE	Disc only	
WEIGHT(kgs) (w/200mm steerer)	1.71	1.66

*A:Air, C:Compression, R:Rebound,RL:Remote Lock-out ,L:Lock-out

*Steerer Tube Options: A. 1.5"Aluminum
B. 1.5" to 1 1/8" Tapered Aluminum





- STEERER
29-15-SRL | 29-15
28.6mm 7050 Aluminum
- ADJUSTMENT
29-15-SRL
Air, Rebound, Compression,
Remote Lockout
29-15
Air, Rebound, Compression, Lockout
- SYSTEM
29-15 | 29-15
OCR-Cartridge Oil(R), Air(L)
- STANCHION
29-15-SRL | 29-15
32mm 7050 Aluminum Hard Anodize
- CASTING
29-15-SRL | 29-15
Magnesium, 15mm QR

CHAMP
RAPID SUSPENSION TECHNOLOGY



CHAMP 29-15



MODEL	29-15-SRL	29-15
STEERER	28.6mm 7050 Aluminum (Optional 1.5" 7050 Aluminum steerer tube)	
CROWN PITCH	130mm	
CROWN	Aluminum Black Coating	
STANCHION	32mm 7050 Aluminum Hard Anodize	
CASTING	Magnesium, 15mm QR	
ADJUSTMENT	A, R, C, RL	A, R, C, L
FEATURES	Air spring, Hydraulic Rebound-adjust, Remote Lock-out	Air spring, Hydraulic Rebound-adjust, Lock-out
SYSTEM	OCR-Cartridge(R), Air(L)	
TRAVEL(mm)	80, 100, 120 mm	
BRAKE TYPE	Disc only	
WEIGHT(kgs) (w/200mm steerer)	1.85	1.80

*A: Air, C: Compression, R: Rebound, RL: Remote Lock-out, L: Lock-out

*Steerer Tube Options: A. 1.5" Aluminum
B. 1.5" to 1 1/8" Tapered Aluminum



- STEERER
29-SRL | 29
28.6mm 7050 Aluminum
- SYSTEM
29-SRL | 29
OCR-Cartridge Oil(R), Air(L)



CHAMP
RAPID SUSPENSION TECHNOLOGY

CHAMP 29



- ADJUSTMENT
29-SRL
Air, Rebound, Compression,
Remote Lockout
29
Air, Rebound,
Compression, Lockout
- STANCHION
29-SRL | 29
32mm 7050 Aluminum
Hard Anodize
- CASTING
29-SRL | 29
Magnesium,
9mm Open Dropout

MODEL	29-SRL	29
STEERER	28.6mm 7050 Aluminum (Optional 1.5" 7050 Aluminum steerer tube)	
CROWN PITCH	130mm	
CROWN	Aluminum Black Coating	
STANCHION	32mm 7050 Aluminum Hard Anodize	
CASTING	Magnesium, 9mm Open Dropout	
ADJUSTMENT	A, R, C, RL	A, R, C, L
FEATURES	Air spring, Hydraulic Rebound-adjust, Remote Lock-out	Air spring, Hydraulic Rebound-adjust, Lock-out
SYSTEM	OCR-Cartridge(R), Air(L)	
TRAVEL(mm)	80, 100, 120 mm	
BRAKE TYPE	Disc only	
WEIGHT(kgs) (w/200mm steerer)	1.66	1.61

*A: Air, C: Compression, R: Rebound, RL: Remote Lock-out, L: Lock-out

*Steerer Tube Options: A. 1.5" Aluminum
B. 1.5" to 1 1/8" Tapered Aluminum



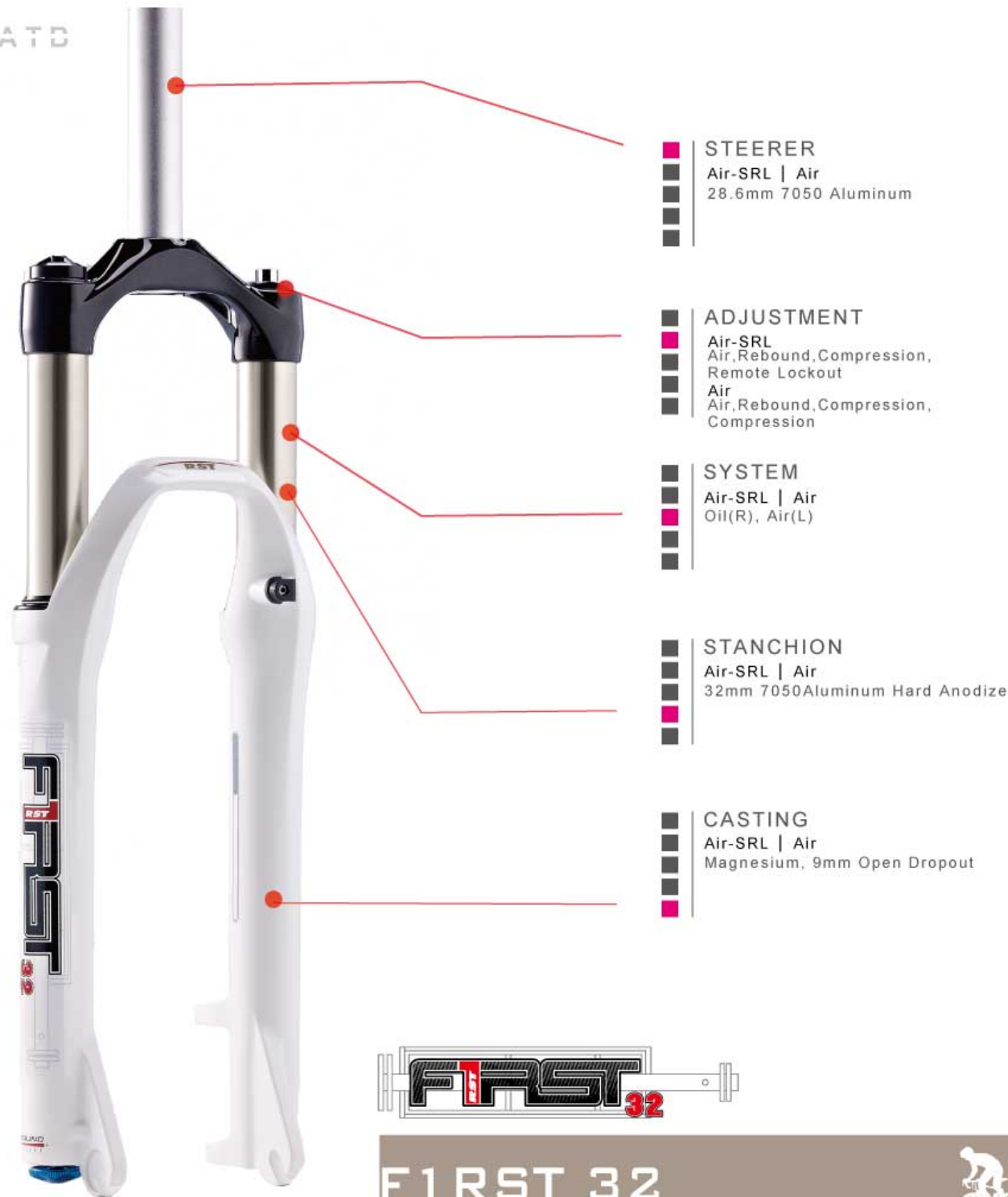

- **STEERER**
Air-SRL | Air
28.6mm 7050 Aluminum
- **ADJUSTMENT**
Air-SRL
Air, Rebound, Compression,
Remote Lockout
Air
Air, Rebound, Compression,
Compression
- **SYSTEM**
Air-SRL | Air
Oil(R), Air(L)
- **STANCHION**
Air-SRL | Air
32mm 7050 Aluminum Hard Anodize
- **CASTING**
Air-SRL | Air
Magnesium, 9mm Open Dropout



FIRST 32



MODEL	Air-SRL	Air
STEERER	28.6mm 7050 Aluminum (Optional 1.5" 7050 Aluminum steerer tube)	
CROWN PITCH	130mm	
CROWN	Aluminum Black Coating	
STANCHION	32mm 7050 Aluminum Hard Anodize	
CASTING	Magnesium, 9mm Open Dropout	
ADJUSTMENT	A, R, C, RL	A, R, C, L
FEATURES	Air spring, Hydraulic Rebound-adjust, Remote Lock-out	Air spring, Hydraulic Rebound-adjust, Lock-out
SYSTEM	Oil(R), Air(L)	
TRAVEL(mm)	80, 100, 120 mm	
BRAKE TYPE	Disc or Disc & V-brake	
WEIGHT(kgs) (w/200mm steerer)	1.85	1.80

*A:Air, C:Compression, R:Rebound, RL:Remote Lock-out ,L:Lock-out

*Steerer Tube Options: A. 1.5"Aluminum
B. 1.5" to 1 1/8" Tapered Aluminum

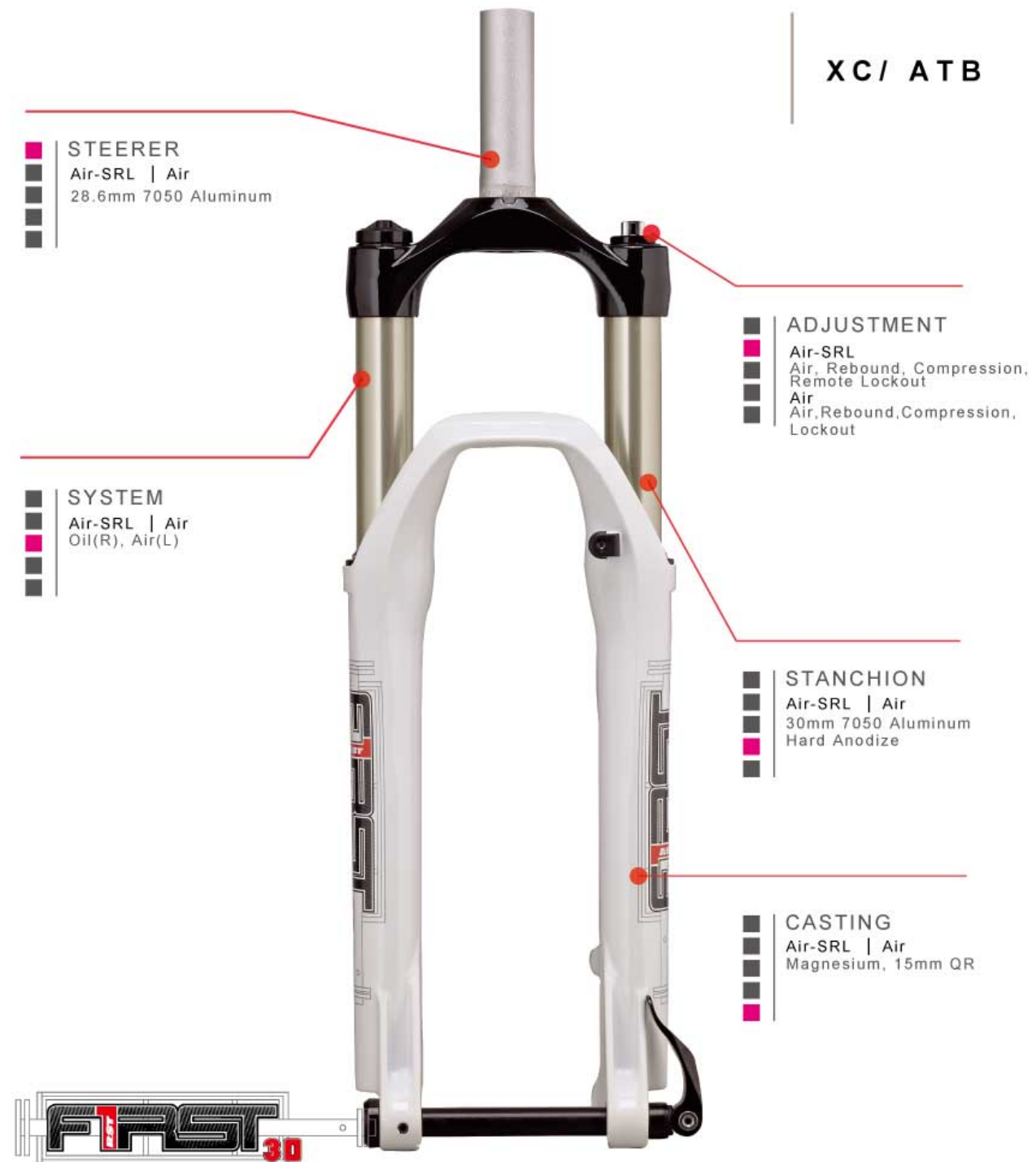

- **STEERER**
Air-SRL | Air
28.6mm 7050 Aluminum
- **ADJUSTMENT**
Air-SRL
Air, Rebound, Compression,
Remote Lockout
Air
Air, Rebound, Compression,
Lockout
- **SYSTEM**
Air-SRL | Air
Oil(R), Air(L)
- **STANCHION**
Air-SRL | Air
30mm 7050 Aluminum
Hard Anodize
- **CASTING**
Air-SRL | Air
Magnesium, 15mm QR



FIRST 30-15



MODEL	Air-SRL	Air
STEERER	28.6mm 7050 Aluminum (Optional 1.5" 7050 Aluminum steerer tube)	
CROWN PITCH	130mm	
CROWN	Aluminum Black Coating	
STANCHION	30mm 7050 Aluminum Hard Anodize	
CASTING	Magnesium, 15mm QR	
ADJUSTMENT	A, R, C, RL	A, R, C, L
FEATURES	Air spring, Hydraulic Rebound-adjust, Remote Lock-out	Air spring, Hydraulic Rebound-adjust, Lock-out
SYSTEM	Oil(R), Air(L)	
TRAVEL(mm)	80, 100, 120 mm	
BRAKE TYPE	Disc only	
WEIGHT(kgs) (w/200mm steerer)	1.98	1.93

*A:Air, C:Compression, R:Rebound, RL:Remote Lock-out ,L:Lock-out

*Steerer Tube Options: A. 1.5"Aluminum
B. 1.5" to 1 1/8" Tapered Aluminum





- **STEERER**
■ Platinum-SRL | Platinum
■ 28.6mm 7050 Aluminum

- **ADJUSTMENT**
■ Platinum-SRL
■ Air,Rebound,Compression,
■ Remote Lockout
■ Platinum
■ Air,Rebound,Compression,Lockout

- **SYSTEM**
■ Platinum-SRL | Platinum
■ Oil(R), Air(L)

- **STANCHION**
■ Platinum-SRL | Platinum
■ 30mm 7050
■ Aluminum Hard Anodize

- **CASTING**
■ Platinum-SRL | Platinum
■ Magnesium, 9mm Open Dropout



FIRST PLATINUM

MODEL	Platinum-SRL	Platinum
STEERER	28.6mm 7050 Aluminum (Optional 1.5" 7050 Aluminum steerer tube)	
CROWN PITCH	130mm	
CROWN	Aluminum Black Coating	
STANCHION	30mm 7050 Aluminum Hard Anodize	
CASTING	Magnesium, 9mm Open Dropout	
ADJUSTMENT	A, R, C, RL	A, R, C, L
FEATURES	Air spring, Hydraulic Rebound-adjust, Remote Lock-out	Air spring, Hydraulic Rebound-adjust, Lock-out
SYSTEM	Oil(R), Air(L)	
TRAVEL(mm)	80, 100mm	
BRAKE TYPE	Disc or Disc & V-brake	
WEIGHT(kgs) (w/200mm steerer)	1.55	1.50

*A:Air, C:Compression, R:Rebound, RL:Remote Lock-out, L:Lock-out

*Steerer Tube Options: A. 1.5"Aluminum
B. 1.5" to 1 1/8" Tapered Aluminum



FIRST 30

MODEL	Air-SRL	Air
STEERER	28.6mm 7050 Aluminum (Optional 1.5" 7050 Aluminum steerer tube)	
CROWN PITCH	130mm	
CROWN	Aluminum Black Coating	
STANCHION	30mm 7050 Aluminum Hard Anodize	
CASTING	Magnesium, 9mm Open Dropout	
ADJUSTMENT	A, R, C, RL	A, R, C, L
FEATURES	Air spring, Hydraulic Rebound-adjust, Remote Lock-out	Air spring, Hydraulic Rebound-adjust, Lock-out
SYSTEM	Oil(R), Air(L)	
TRAVEL(mm)	80, 100mm	
BRAKE TYPE	Disc or Disc & V-brake	
WEIGHT(kgs) (w/200mm steerer)	1.80	1.75

*A:Air, C:Compression, R:Rebound, RL:Remote Lock-out, L:Lock-out
*Steerer Tube Options:
A. 1.5"Aluminum
B. 1.5" to 1 1/8" Tapered Aluminum



FIRST 24

MODEL	Air-SRL	Air
STEERER	28.6mm 7050 Aluminum	
CROWN PITCH	125mm	
CROWN	Aluminum Black Coating	
STANCHION	28.6mm 7050 Aluminum Hard Anodize	
CASTING	Magnesium, 9mm Open Dropout	
ADJUSTMENT	A, R, C, RL	A, R, C, L
FEATURES	Air spring, Hydraulic Rebound-adjust, Remote Lock-out	Air spring, Hydraulic Rebound-adjust, Lock-out
SYSTEM	Oil(R), Air(L)	
TRAVEL(mm)	60mm	
BRAKE TYPE	Disc & V-brake	
WEIGHT(kgs) (w/200mm steerer)	1.65	1.60

A:Air, C:Compression, R:Rebound, RL:Remote Lock-out, L:Lock-out





- STEERER
Air-SRL | Air
28.6mm 7050 Aluminum
- ADJUSTMENT
Air-SRL
Air, Rebound, Compression, Remote Lockout
Air
Air, Rebound, Compression, Lockout
- SYSTEM
Air-SRL | Air
Oil(R), Air(L)
- STANCHION
Air-SRL | Air
32mm 7050 Aluminum Hard Anodize
- CASTING
Air-SRL | Air
Magnesium, 15mm QR



FIRST 29-15



MODEL	Air-SRL	Air
STEERER	28.6mm 7050 Aluminum (Optional 1.5" 7050 Aluminum steerer tube)	
CROWN PITCH	130mm	
CROWN	Aluminum Black Coating	
STANCHION	32mm 7050 Aluminum Hard Anodize	
CASTING	Magnesium, 15mm QR	
ADJUSTMENT	A, R, C, RL	A, R, C, L
FEATURES	Air spring, Hydraulic Rebound-adjust , Remote Lock-out	Air spring, Hydraulic Rebound-adjust, Lock-out
SYSTEM	Oil(R), Air(L)	
TRAVEL(mm)	80, 100, 120mm	
BRAKE TYPE	Disc Only	
WEIGHT(kgs) (w/200mm steerer)	2.18	2.13

*A:Air, C:Compression, R:Rebound, RL:Remote Lock-out ,L:Lock-out

*Steerer Tube Options: A. 1.5"Aluminum
B. 1.5" to 1 1/8" Tapered Aluminum



- STEERER
Air-SRL | Air
28.6mm 7050 Aluminum
- SYSTEM
Air-SRL | Air
Oil(R), Air(L)
- ADJUSTMENT
Air-SRL
Air, Rebound, Compression,
Remote Lockout
Air
Air, Rebound,
Compression, Lockout
- STANCHION
Air-SRL | Air
32mm 7050 Aluminum
Hard Anodize
- CASTING
Air-SRL | Air
Magnesium,
9mm Open Dropout



FIRST 29



MODEL	Air-SRL	Air
STEERER	28.6mm 7050 Aluminum (Optional 1.5" 7050 Aluminum steerer tube)	
CROWN PITCH	130mm	
CROWN	Aluminum Black Coating	
STANCHION	32mm 7050 Aluminum Hard Anodize	
CASTING	Magnesium, 9mm Open Dropout	
ADJUSTMENT	A, R, C, RL	A, R, C, L
FEATURES	Air spring, Hydraulic Rebound-adjust , Remote Lock-out	Air spring, Hydraulic Rebound-adjust, Lock-out
SYSTEM	Oil(R), Air(L)	
TRAVEL(mm)	80, 100, 120 mm	
BRAKE TYPE	Disc only	
WEIGHT(kgs) (w/200mm steerer)	1.99	1.94

*A:Air, C:Compression, R:Rebound, RL:Remote Lock-out ,L:Lock-out

*Steerer Tube Options: A. 1.5"Aluminum
B. 1.5" to 1 1/8" Tapered Aluminum





- STEERER
RL | TNL | ML
28.6mm steel
- ADJUSTMENT
RL
Air, Remote Lockout
TNL
Air, Lockout
ML
Air, Lockout
- SYSTEM
RL | TNL
Air, Oil(R)
ML
Air(L)
- STANCHION
RL | TNL | ML
32mm Steel Ti Color
- CASTING
RL | TNL | ML
Magnesium, 9mm Open Dropout

AERIAL 32



MODEL	RL	TNL	ML
STEERER	28.6mm steel (Optional 1.5" 7050 Aluminum steerer tube)		
CROWN PITCH	130mm		
CROWN	Aluminum Black Coating		
STANCHION	32mm Steel Ti Color		
CASTING	Magnesium, 9mm Open Dropout		
ADJUSTMENT	A, RL	A, L	A, L
FEATURES	Air spring, Hydraulic Remote Lock-out	Air spring, Hydraulic Lock-out	Air spring, Mechanical Lock-Out
SYSTEM	Oil(R), Air(L)		Air
TRAVEL(mm)	80, 100, 120 mm		
BRAKE TYPE	Disc or Disc & V-brake		
WEIGHT(kgs) (w/200mm steerer)	2.45	2.37	2.14

*A:Air, RL:Remote Lock-out ,L:Lock-out



- STEERER
RL | TNL | ML
28.6mm steel

- SYSTEM
RL | TNL
Air, Oil(R)
ML
Air(L)



- ADJUSTMENT
RL
Air, Remote Lockout
TNL
Air, Lockout
ML
Air, Lockout
- STANCHION
RL | TNL | ML
30mm Steel Ti Color
- CASTING
RL | TNL | ML
Magnesium,
9mm Open Dropout

AERIAL 30



MODEL	RL	TNL	ML
STEERER	28.6mm steel (Optional 1.5" 7050 Aluminum steerer tube)		
CROWN PITCH	130mm		
CROWN	Aluminum Black Coating		
STANCHION	30mm Steel Ti Color		
CASTING	Magnesium, 9mm Open Dropout		
ADJUSTMENT	A, RL	A, L	A, L
FEATURES	Air spring, Hydraulic Remote Lock-out	Air spring, Hydraulic Lock-out	Air spring, Mechanical Lock-out
SYSTEM	Oil(R), Air(L)		Air
TRAVEL(mm)	80, 100, 120 mm		
BRAKE TYPE	Disc or Disc & V-brake		
WEIGHT(kgs) (w/200mm steerer)	2.34	2.27	2.01

*A:Air, R:Rebound, L:Lock-out





- STEERER
RL | TNL | ML
28.6mm Steel
- ADJUSTMENT
RL
Air, Remote Lockout
TNL
Air, Lockout
ML
Air, Lockout
- SYSTEM
RL | TNL
Oil(R), Air(L)
ML
Air
- STANCHION
RL | TNL | ML
32mm Steel Ti Color
- CASTING
RL | TNL | ML
Magnesium, 9mm Open Dropout



AERIAL 29



MODEL	RL	TNL	ML
STEERER	28.6mm steel (Optional 1.5" 7050 Aluminum steerer tube)		
CROWN PITCH	130mm		
CROWN	Aluminum Black Coating		
STANCHION	32mm Steel Ti Color		
CASTING	Magnesium, 9mm Open Dropout		
ADJUSTMENT	A, RL	A, L	A, L
FEATURES	Air spring, Hydraulic Remote Lock-out	Air spring, Hydraulic Lock-out	Air spring, Mechanical Lock-out
SYSTEM	Oil(R), Air(L)		
TRAVEL(mm)	80, 100, 120 mm		
BRAKE TYPE	Disc only		
WEIGHT(kgs) (w/200mm steerer)	2.48	2.40	2.17

*A: Air, RL: Remote Lock-out, L: Lock-out



OMEGA



MODEL	RL	TNL	ML	T
STEERER	28.6mm Steel			
CROWN PITCH	130mm			
CROWN	Aluminum ED Black			
STANCHION	30mm Steel Ti Color			
CASTING	Magnesium, 9mm Open Dropout			
ADJUSTMENT	RL, P (Easy preload)	L, P (Easy preload)	L, P (Easy preload)	P (Easy preload)
FEATURES	Hydraulic Remote Lock-out	Hydraulic Lock-out	Mechanical Lock-out	-
SYSTEM	Oil(R), Coil(L)			
TRAVEL(mm)	80, 100, 120 mm			
BRAKE TYPE	Disc or Disc & V-brake			
WEIGHT(kgs) (w/200mm steerer)	2.44	2.37	2.11	2.11

*RL: Remote Lock-out, L: Lock-out, P: Preload



OMEGA 29



MODEL	RL	TNL	ML	T
STEERER	28.6mm Steel			
CROWN PITCH	130mm			
CROWN	Aluminum ED Black			
STANCHION	32mm Steel Ti Color			
CASTING	Magnesium, 9mm Open Dropout			
ADJUSTMENT	RL, P (Easy preload)	L, P (Easy preload)	L, P (Easy preload)	P (Easy preload)
FEATURES	Hydraulic Remote Lock-out	Hydraulic Lock-out	Mechanical Lock-out	-
SYSTEM	Oil(R), Coil(L)			
TRAVEL(mm)	80, 100, 120 mm			
BRAKE TYPE	Disc only			
WEIGHT(kgs) (w/200mm steerer)	2.55	2.47	2.24	2.24

*RL: Remote Lock-out, L: Lock-out, P: Preload



BLAZE

BLAZE



MODEL	RL	TNL	ML	T
STEERER		28.6mm Steel		
CROWN PITCH		125mm		
CROWN		Aluminum ED Black		
STANCHION		30mm Steel CP Finish		
CASTING		Aluminum, 9mm Open Dropout		
ADJUSTMENT	RL, P	L, P	L, P	-
FEATURES	Hydraulic Remote Lock-out	Hydraulic Lock-out	Mechanical Lock-out	-
SYSTEM		Oil(R), Coil(L)		Coil
TRAVEL(mm)		80, 100, 120 mm		
BRAKE TYPE		Disc or Disc & V-brake		
WEIGHT(kgs) (w/200mm steerer)	2.62	2.55	2.30	2.34

*RL:Remote Lock-out ,L:Lock-out ,P:Preload



GILA

GILA



MODEL	RL	TNL	ML	T
STEERER		28.6mm Steel		
CROWN PITCH		125mm		
CROWN		Aluminum ED Black		
STANCHION		28.6mm Steel CP Finish		
CASTING		Aluminum, 9mm Open Dropout		
ADJUSTMENT	RL,P	L,P	L,P	-
FEATURES	Hydraulic Remote Lock-out	Hydraulic Lock-out	Mechanical Lock-Out	-
SYSTEM		Oil(R), Coil(L)		Coil
TRAVEL(mm)		80, 100mm		
BRAKE TYPE		Disc or Disc & V-brake		
WEIGHT(kgs) (w/200mm steerer)	2.42	2.35	2.10	2.05

*RL:Remote Lock-out ,L:Lock-out ,P:Preload



BLAZE²⁹

BLAZE 29



MODEL	RL	TNL	ML	T
STEERER		28.6mm Steel		
CROWN PITCH		130mm		
CROWN		Aluminum ED Black		
STANCHION		30mm Steel CP Finish		
CASTING		Aluminum, 9mm Open Dropout		
ADJUSTMENT	RL,P	L,P	L,P	P
FEATURES	Hydraulic Remote Lock-out	Hydraulic Lock-out	Mechanical Lock-out	-
SYSTEM		Oil(R), Coil(L)		Coil
TRAVEL(mm)		80, 100, 120 mm		
BRAKE TYPE		Disc or Disc & V-brake		
WEIGHT(kgs) (w/200mm steerer)	2.92	2.84	2.61	2.61

*RL:Remote Lock-out ,L:Lock-out ,P:Preload



CAPA

CAPA



MODEL	ML 26, 24	T26, T24, T20
STEERER		28.6/25.4mm Steel
CROWN PITCH		120mm
CROWN		Aluminum ED Black
STANCHION		25.4mm Steel CP Finish
CASTING		Aluminum, 9mm Open Dropout
ADJUSTMENT	L, P	-
FEATURES	Mechanical Lock-out	-
SYSTEM	Coil	Coil
TRAVEL(mm)	ML26" : 80mm / ML24" : 50 mm	T26" : 80 mm / T24" : 50 mm / T20" : 50 mm
BRAKE TYPE		Disc & V-brake
WEIGHT(kgs) (w/200mm steerer)	ML26" : 2.03 / ML24" : 1.98	T26" : 1.98 / T24" : 1.84 / T20" : 1.75

*L:Lock-out ,P:Preload





XC/650B

The revolution is back!

**XC/
650B**



STEERER
RL | TNL | ML | T
28.6mm

ADJUSTMENT
RL TNL
RL, P L, P
ML T
L, P T, P

SYSTEM
RL | TNL | ML
Oil(R), Coil(L)
T
Coil

STANCHION
RL | TNL | ML | T
30mm Steel CP Finish

CASTING
RL | TNL | ML | T
Aluminum, 9mm Open Dropout

BLAZE^{650B}
RST

BLAZE 650B



MODEL	RL	TNL	ML	T
STEERER	28.6mm Steel (Optional 1.5" Aluminum steerer tube)			
CROWN PITCH	130mm			
CROWN	Aluminum ED Black			
STANCHION	30mm Steel CP Finish			
CASTING	Aluminum, 9mm Open Dropout			
ADJUSTMENT	RL,P	L,P	L,P	P
FEATURES	Hydraulic Remote Lock-out	Hydraulic Lock-out	Mechanical Lock-Out	-
SYSTEM	Oil(R), Coil(L)			Coil
TRAVEL(mm)	100, 120, 130 mm			
BRAKE TYPE	Disc only			
WEIGHT(kgs) (w/200mm steerer)	2.83	2.76	2.51	2.55

*P:Preload, RL:Remote Lock-out ,L:Lock-out





DIRT JUMP

Develop from BMX riding style with 26" wheel. It required most skilled rider to perform tricks over concrete obstacle. The forks for Dirt jump bike need durable structure, shorter travel and high performance hydraulic system.

DIRT/
JUMP



MODEL	Jump TA or QR	Free TA or QR
STEERER	28.6mm 7050 Aluminum	28.6mm Cr-mo steel
CROWN PITCH	138mm	
CROWN	Aluminum Black Coating	
STANCHION	36mm 7050 Aluminum Hard Anodize	36mm Cr-mo steel Ti color
CASTING	Magnesium, 20mm Alloy Thru-axle	
ADJUSTMENT	A, R	R
FEATURES	Air spring, Hydraulic Rebound-adjust Oil(R), Air(L)	Hydraulic Rebound-adjust, Oil(R), Coil/MCU(L)
SYSTEM	Oil(R), Air(L)	
TRAVEL(mm)	80, 100mm	
BRAKE TYPE	Disc Only	
WEIGHT(kgs) (w/200mm steerer)	2.63	2.93

*A:Air, R:Rebound, TA: Through Axle, QR: Quick Adapter



DIRT

MODEL	RA	T
STEERER	28.6mm Steel	
CROWN PITCH	130mm	
CROWN	Aluminum ED Black	
STANCHION	32mm Steel CP Finish	
CASTING	Aluminum, 9mm Open Dropout	
ADJUSTMENT	R, P	P
FEATURES	Hydraulic Rebound-adjust, Preload	Preload
SYSTEM	Oil(R), Coil(L)	Coil
TRAVEL(mm)	80, 100, 130 mm	
BRAKE TYPE	Disc or Disc & V-brake	
WEIGHT(kgs) (w/200mm steerer)	3.01	3.05

*R:Rebound, P:Preload



CROSS TREKKING

TREKKING

Riding along gravel roads for expedition and leisure exercise purpose. Trekking bike front fork needs compatible design with hub dynamo, roller brake and fender...
In addition, it also needs light weight specification and also need minimum 50mm travel if encounter some bumps while pedaling.

■ Testing Standard of E-BIKE/Pedelec

Test requirement

E-BIKE

1. Bending Fatigue test exceeding DIN-EN 14764 (4.9.6): 620N, 100.000 cycles.
2. Emergency braking test: according to old DIN 79100 - force increased to 1800N.
3. The other test refer to DIN-EN 14781
4. Test frequency 4 Hz.

Pedelec

1. Bending Fatigue test exceeding DIN-EN 14764 (4.9.6): 500N, 100.000 cycles.
2. Emergency braking test: according to old DIN 79100 - force increased to 1800N.
3. The other test refer to DIN-EN14764
4. Test frequency 4 Hz.

Taipei

Frankfurt

Prague

Moscow

Sao Paulo





- STEERER
Air-SRL | Air
28.6mm 7050 Aluminum
- ADJUSTMENT
Air-SRL
Air, Rebound, Compression, Remote Lockout
Air
Air, Rebound, Compression, Lockout
- SYSTEM
Air-SRL | Air
Oil(R), Air(L)
- STANCHION
Air-SRL | Air
28.6mm 7050
Aluminum Hard Anodize
- CASTING
Air-SRL | Air
Magnesium, 9mm Open Dropout

VOGUE

VOGUE



Suitable for : Pedelec Only

MODEL	Air-SRL	Air
STEERER	28.6mm 7050 Aluminum	
CROWN PITCH	112mm	
CROWN	Aluminum Black Coating	
STANCHION	28.6mm 7050 Aluminum Hard Anodize	
CASTING	Magnesium, 9mm Open Dropout	
ADJUSTMENT	A, R, C, RL	A, R, C, L
FEATURES	Air spring, Hydraulic Rebound-adjust Remote Lock-out	Air spring, Hydraulic Rebound-adjust, Lock-out
SYSTEM	Oil(R), Air(L)	
TRAVEL(mm)	700C: 50, 60, 75 mm	
BRAKE TYPE	Disc or Disc & V-brake	
WEIGHT(kgs) (w/200mm steerer)	1.68	1.63

*A:Air, C:Compression, R:Rebound, RL:Remote Lock-out ,L:Lock-out



- STEERER
RL | TNL | ML | T
28.6/25.4mm Steel
- SYSTEM
RL | TNL
Oil(R), Coil(L)
ML | T
Coil
- ADJUSTMENT
RL
Remote Lockout, Preload
TNL
Lockout, Preload
ML
Lockout, Preload
T
Preload
- STANCHION
RL | TNL | ML | T
28.6mm Steel Ti Color
- CASTING
RL | TNL | ML | T
Magnesium, 9mm Open Dropout

RST VITA

VITA



Suitable for : Pedelec Only

MODEL	RL	TNL	ML	T
STEERER	28.6/25.4mm Steel			
CROWN PITCH	112mm			
CROWN	Aluminum ED Black			
STANCHION	28.6mm Steel Ti Color			
CASTING	Magnesium, 9mm Open Dropout			
ADJUSTMENT	RL, P (Easy preload)	L, P (Easy preload)	L, P (Easy preload)	P (Easy preload)
FEATURES	Hydraulic Remote Lock-out	Hydraulic Lock-out	Mechanical Lock-Out	—
SYSTEM	Oil(R), Coil(L)			Coil
TRAVEL(mm)	700C : 50, 60 mm			
BRAKE TYPE	Disc or Disc & V-brake			
WEIGHT(kgs) (w/200mm steerer)	2.28	2.20	1.98	1.98

*RL:Remote Lock-out ,L:Lock-out



RST NEON

NEON PLS

Suitable for : E-BIKE and Pedelec

MODEL	RL	ML	T
STEERER		28.6/25.4 mm Steel	
CROWN PITCH		112mm	
CROWN		Aluminum ED Black	
STANCHION		28.6mm Steel CP Finish	
CASTING		Aluminum, 9mm Open Dropout	
ADJUSTMENT	RL, P	L, P	P
FEATURES	Hydraulic Remote Lock-out	Mechanical Lock-Out	-
SYSTEM	Oil(R), Coil(L)		Coil
TRAVEL(mm)		700C: 50, 60 mm	
BRAKE TYPE		Disc or Disc & V-brake	
WEIGHT(kgs) (w/200mm steerer)	2.59	2.30	2.31

*RL:Remote Lock-out ,L:Lock-out ,P:Preload



RST SOFL

SOFI PLS

Suitable for : E-BIKE and Pedelec

MODEL	RL	ML	T
STEERER		28.6/25.4 mm Steel	
CROWN PITCH		112mm	
CROWN		Aluminum ED Black	
STANCHION		28.6mm Steel CP Finish	
CASTING		Aluminum, 9mm Open Dropout	
ADJUSTMENT	RL, P	L, P	P
FEATURES	Hydraulic Remote Lock-out	Mechanical Lock-Out	-
SYSTEM	Oil(R), Coil(L)		Coil
TRAVEL(mm)		700C: 40, 50 mm	
BRAKE TYPE		V-brake only	
WEIGHT(kgs) (w/200mm steerer)	2.59	2.30	2.31

RL: Remote lockout, L: Lock-out, P: Preload



PLS



PLS-Front



PLS-Back

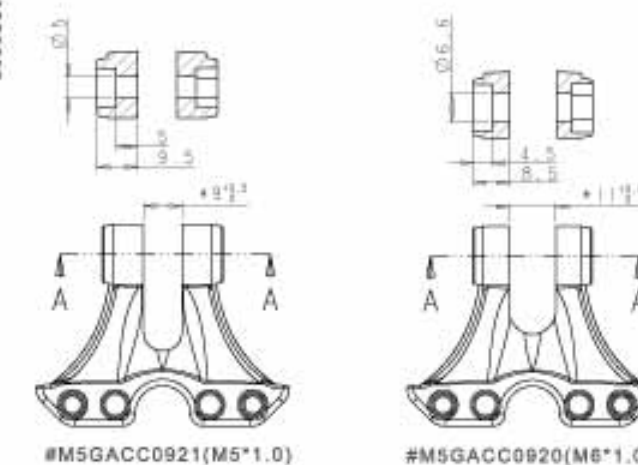

#M5GACC0921 for TRELOCK and BASTA using.; #M5GACC0920 for BUMM using

PLS INFO.



Front Light Maker	RST bracket part #	Available model
BUMM	M5GACC0920 (using M8 Screw)	LUMOTEC Classic LUMOTEC Lyt B LUMOTEC LYT LUMOTEC IQ Fly (T) LUMOTEC IQ Cyo (T) LUMOTEC rund LUMOTEC Retro LUMOTEC oval
BASTA	M5GACC0921 (using M5 Screw)	Sprint
TRELOCK	M5GACC0921 (using M5 Screw)	LS 850 series / LS 870 series Bird series

RST NEON

NEON



MODEL	RL	ML	T
STEERER		28.6/25.4 mm Steel	
CROWN PITCH		112mm	
CROWN		Aluminum ED Black	
STANCHION		25.4mm Steel CP Finish	
CASTING		Aluminum, 9mm Open Dropout	
ADJUSTMENT	RL, P	L, P	P
FEATURES	Hydraulic Remote Lock-out	Mechanical Lock-Out	-
SYSTEM	Oil(R), Coil(L)		Coil
TRAVEL(mm)		700C: 50, 60 mm	26": 75mm
BRAKE TYPE		Disc & V-brake	
WEIGHT(kgs) (w/200mm steerer)	2.19	1.95	1.94

*RL:Remote Lock-out , P:Preload



SS-M6

SS-M7 T



700C 26" SS-M7 T SS-M6 T SS-M7 SS-M6

MODEL	SS-M7-T	SS-M7	SS-M6-T	SS-M6
WHEEL SIZE	700C	26"		
TRAVEL(mm)	30mm	35mm	30mm	35mm
FEATURES	Mag. Blade Spring Preload	Mag. Blade	Mag. Blade Spring Preload	Mag. Blade
STEERER	28.6 mm 7050 Aluminum (Min. length: 200mm)			
LOWER	Aluminum, 9mm Open Dropout			
BRAKE TYPE	Disc + V-brake(Optional Roller Mount)			
WEIGHT(kgs) (w/200mm steerer)	1.33	1.33	1.18	1.18

RST SOFI

SOFI



Suitable for : Pedelec Only

MODEL	RL	ML	T
STEERER		28.6/25.4 mm Steel	
CROWN PITCH		112mm	
CROWN		Aluminum ED Black	
STANCHION		25.4mm Steel CP Finish	
CASTING		Aluminum, 9mm Open Dropout	
ADJUSTMENT	RL, P	L, P	P
FEATURES	Hydraulic Remote Lock-out	Mechanical Lock-Out	-
SYSTEM	Oil(R), Coil(L)		Coil
TRAVEL(mm)		700C: 50, 60 mm	26": 50,mm
BRAKE TYPE		V-brake only	
WEIGHT(kgs) (w/200mm steerer)	2.32	2.06	2.07

*RL:Remote Lock-out , L:Lock-out , P:Preload



SINGLE SHOCK



SS-A7 T



SS-A7 T | SS-A7
SS-A6 T | SS-A6



SS-A7 T / SS-A7 / SS-A6 suitable for : E-BIKE and Pedelec

SS-A6 T suitable for : Pedelec only

MODEL	SS-A7-T	SS-A7	SS-A6-T	SS-A6
WHEEL SIZE	700C		26"	
TRAVEL(mm)	30mm	35mm	30mm	35mm
FEATURES	Alu. Blade Spring Preload	Alu. Blade	Alu. Blade Spring Preload	Alu. Blade
STEERER	28.6 mm 7050 Aluminum (Min. length: 200mm)			
LOWER	Aluminum, 9mm Open Dropout			
BRAKE TYPE	Disc or Disc + V-brake(Optional Roller Mount)			
WEIGHT(kgs) (w/200mm steerer)	1.60	1.60	1.52	1.52



SS-A2



SS-A4 T | SS-A2-100
SS-A4 | SS-A2-75



SS-A4 / SS-A2-100 / SS-A2-75 suitable for : E-BIKE and Pedelec

SS-A4 T suitable for : Pedelec only

MODEL	SS-A4 T	SS-A4	SS-A2-100	SS-A2-75
WHEEL SIZE	24"		20"	
TRAVEL(mm)	30mm	30mm	30mm	30mm
FEATURES	Alu. Blade Spring Preload	Alloy Blade	Alloy Blade (straight) Dropout pitch 100mm	Alloy Blade (curve) Dropout pitch 75mm
STEERER	28.6 mm 7050 Aluminum (Min. length: 200mm)			
LOWER	Aluminum, 9mm Open Dropout			
BRAKE TYPE	Disc + V-brake	Disc + V-brake	Disc + V-brake	V-brake only
WEIGHT(kgs) (w/200mm steerer)	1.51	1.45	1.32	1.28

RIGID FORK

RF-M6



RF-M7

RF-M7 | RF-M6



MODEL	RF-M7	RF-M6
WHEEL SIZE	700C	26"
TRAVEL(mm)	N/A	
FEATURES	Mag. Blade	
STEERER	28.6 mm 7050 Aluminum	
LOWER	9mm Open Dropout Aluminum	
BRAKE TYPE	Disc + V-brake (Optional Roller Mount)	
WEIGHT(kgs) (w/200mm steerer)	0.83	0.75



ELEMENT



LO



MODEL	LO
Body/Finish	Alloy, Hard Anodized in Black
Spring System	Air Spring
Damping System	Hydraulic Damping
Eye To Eye / Travel(mm)	150x25, 165x35, 190x45, 200x50
Bolt Diameter	8mm or 6mm
WEIGHT(kgs)	215g(150mm) / 225g(165mm)
(w/200mm steerer)	245g(190mm) / 255g(200mm)



DIMENTION

unit: mm

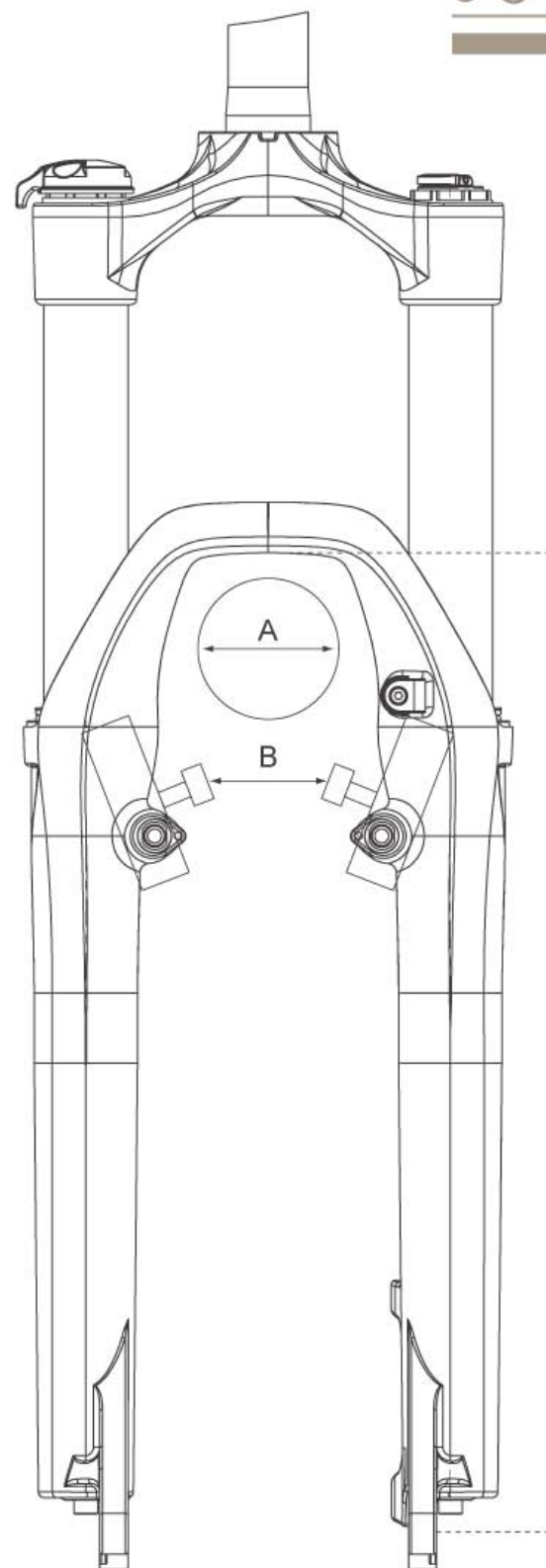

MODEL NAME	WIDTH A	WIDTH B	WIDTH C	MAXIMUM ROTOR SIZE
R 1	<69	00	350	203
STORM	<69	00	350	203
SPACE	<69	00	350	203
TITAN 15	<67	00	350	203
TITAN	<67	58	350	203
F1RST 32	<55	58	349	180
CHAMP 32	<55	58	349	180
CHAMP 30-15	<55	00	350	180
CHAMP 29-15	<69	00	380	180
CHAMP 29	<69	00	380	180
F1RST 30-15	<55	00	350	180
F1RST 30	<55	58	350	180
F1RST 24	<55	54	317	180
F1RST 29-15	<69	00	380	180
F1RST 29	<69	00	380	180
VOGUE	<55	54	377	180
OMEGA 29	<69	00	380	180
OMEGA	<55	58	350	180
DIRT	<56	58	351	180
BLAZE 29	<56	63	380	180
BLAZE	<59	63	350	180
BLAZE 650 B	<62	00	717	180
GILA	<58	60	355	180
CAPA 26/24/20	<58	54	352/322/289	160
VITA	<58	56	376	180
NEON-PLS	<57	54	378	180
NEON 700/26	<57	54	382/360	180
SOFI-PLS	<57	54	378	000
SOFI 700/26	<55	50	375/355	000
SS-M7	<45	45	380	160
RF-M7	<45	45	380	160
SS-A7	<45	45	365	180
SS-M6	<50	45	345	160
RF-M6	<50	45	345	160
SS-A6	<50	45	345	180
SS-A4	<45	45	318	160
SS-A2-100	<32	44	265	160
SS-A2-75	<32	38	265	000

Bike Category	Down hill R1			Free ride STORM			All Mountain Titan 75			All Mountain Titan		
	Platform	Super	Platform	AIR	SUPER	Platform	AIR-SRL	AIR	Platform	AIR	SUPER	
Model	28.6mm 7050 Aluminum	28.6mm 7050 Aluminum	28.6mm 7050 Aluminum	28.6mm 7050 Aluminum	28.6mm 7050 Aluminum	28.6mm 7050 Aluminum	28.6mm 7050 Aluminum	28.6mm 7050 Aluminum	28.6mm 7050 Aluminum	28.6mm 7050 Aluminum	28.6mm 7050 Aluminum	
Steerer	Option	Option	Option	Option	Option	Option	Option	Option	Option	Option	Option	
1.5" Steerer (Straight or Taper)	—	—	—	—	—	—	—	—	—	—	—	
Crown	138mm-Dual Aluminum, Satin Black	138mm-Dual Aluminum, Satin Black	138mm Aluminum, Black Coating	138mm Aluminum, Black Coating	138mm Aluminum, Black Coating	130mm Aluminum, Black Coating	130mm Aluminum, Black Coating	130mm Aluminum, Black Coating	130mm Aluminum, Black Coating	130mm Aluminum, Black Coating	130mm Aluminum, Black Coating	
Stanchion	36mm 7050 Aluminum Hard Anodize	36mm 7050 Aluminum Hard Anodize	36mm 7050 Aluminum Hard Anodize	36mm 7050 Aluminum Hard Anodize	36mm 7050 Aluminum Hard Anodize	32mm 7050 Aluminum Hard Anodize	32mm 7050 Aluminum Hard Anodize	32mm 7050 Aluminum Hard Anodize	32mm 7050 Aluminum Hard Anodize	32mm 7050 Aluminum Hard Anodize	32mm 7050 Aluminum Hard Anodize	
Lower	Magnesium 20mm Thru-Axle	Magnesium 20mm Thru-Axle	Magnesium 20mm Thru-Axle	Magnesium 20mm Thru-Axle	Magnesium 20mm Thru-Axle	Magnesium 15mm QR	Magnesium 15mm QR	Magnesium 15mm QR	Magnesium 9mm Open Dropout	Magnesium 9mm Open Dropout	Magnesium 9mm Open Dropout	
Feature	Platform High/Low speed compression, Rebound Adjust	Hydraulic Compression and Rebound Adjust	Hydraulic Compression and Rebound Adjust	Hydraulic Compression and Rebound Adjust	Hydraulic Compression and Rebound Adjust	High/Low speed compression, Rebound Adjust, w/ air spring	High/Low speed compression, Rebound Adjust, w/ Air spring	Hydraulic Rebound-adjust Lock-out, Air spring	Platform High/Low speed compression, Rebound Adjust, w/ Air spring	Hydraulic Compression and Rebound Adjust Air spring	Hydraulic Rebound-adjust Lock-out, Air spring	
Damper	OCR Platform	OCR2	OCR	OCR2	Hydraulic Cartridge	OCR Platform	OCR	OCR	OCR Platform	OCR	OCR	
Spring	Coil	Coil	Air	Air	Coil	Air	Air	Air	Air	Air	Air	
Adjustment	R,C,F	R,C	A,R,C	A,R,C	R	A,R,C,F	A,R,R,L,C	A,R,L,C	A,R,C,F	A,R,R,L,C	A,R,L,C	
Travel	180 mm	180 mm	140, 160, 180 mm	140, 160, 180 mm	140, 150 mm	140, 150 mm	140, 150 mm	140 mm	140 mm	140 mm	140 mm	
Fork offset	43mm	43mm	43mm	43mm	43mm	43mm	43mm	43mm	43mm	43mm	43mm	
Fork height (mm)	555	555	520 / 540 / 560	520 / 540 / 560	520 / 530	520 / 530	520 / 530	520	520	520	520	
Seal/Boot	spring seal	spring seal	spring seal	spring seal	spring seal	spring seal	spring seal	spring seal	spring seal	spring seal	spring seal	
Brake Type	Disc only	Disc only	Disc only	Disc only	Disc only	Disc only	Disc only	Disc or D+V	Disc or D+V	Disc or D+V	Disc or D+V	
Disc Brake Mount	Post	Post	Post	Post	Post	Post	Post	Post	Post	Post	Post	
Recommended Max. Rotor Size in mm	203	203	203	203	203	203	203	203	203	203	203	
Dynamo Bracket Mount	—	—	—	—	—	—	—	—	—	—	—	
Cable Guide for Hub Dynamo	—	—	—	—	—	—	—	—	—	—	—	
Roller Brake Mount	—	—	—	—	—	—	—	—	—	—	—	
Weight (kgs) (w/steerer at 200mm)	3.28	3.28	2.50	2.50	3.00	2.19	2.19	2.14	2.04	2.04	1.99	
Wheel size	26"	26"	26"	26"	26"	26"	26"	26"	26"	26"	26"	
Origin of Production	Taiwan	Taiwan	Taiwan	Taiwan	Taiwan	Taiwan	Taiwan	Taiwan	Taiwan	Taiwan	Taiwan	
2013 VS 2012	—	—	—	—	—	—	—	—	—	—	—	
Remarks	—	—	—	—	—	—	—	—	—	—	—	

Bike Category	XC			CHAMP			FIRST 32			FIRST 30-15		
	32-SRL	32	30-15-SRL	30-15	29-15-SRL	29-15	29-SRL	29	AIR-SRL	AIR	AIR-SRL	AIR-SRL
Model	28.6mm 7050 Aluminum	28.6mm 7050 Aluminum	28.6mm 7050 Aluminum	28.6mm 7050 Aluminum	28.6mm 7050 Aluminum	28.6mm 7050 Aluminum	28.6mm 7050 Aluminum	28.6mm 7050 Aluminum	28.6mm 7050 Aluminum	28.6mm 7050 Aluminum	28.6mm 7050 Aluminum	28.6mm 7050 Aluminum
Steerer	Option	Option	Option	Option	Option	Option	Option	Option	Option	Option	Option	Option
1.5" Steerer (Straight or Taper)	—	—	—	—	—	—	—	—	—	—	—	—
Crown	130mm Aluminum, Black Coating	130mm Aluminum, Black Coating	130mm Aluminum, Black Coating	130mm Aluminum, Black Coating	130mm Aluminum, Black Coating	130mm Aluminum, Black Coating	130mm Aluminum, Black Coating	130mm Aluminum, Black Coating	130mm Aluminum, Black Coating	130mm Aluminum, Black Coating	130mm Aluminum, Black Coating	130mm Aluminum, Black Coating
Stanchion	32mm 7050 Aluminum Hard Anodize	32mm 7050 Aluminum Hard Anodize	30mm 7050 Aluminum Hard Anodize	32mm 7050 Aluminum Hard Anodize	32mm 7050 Aluminum Hard Anodize	32mm 7050 Aluminum Hard Anodize	32mm 7050 Aluminum Hard Anodize	32mm 7050 Aluminum Hard Anodize	32mm 7050 Aluminum Hard Anodize	32mm 7050 Aluminum Hard Anodize	32mm 7050 Aluminum Hard Anodize	32mm 7050 Aluminum Hard Anodize
Lower	9mm Open Dropout	9mm Open Dropout	15mm QR	15mm QR	15mm QR	15mm QR	9mm Open Dropout	9mm Open Dropout	9mm Open Dropout	9mm Open Dropout	9mm Open Dropout	9mm Open Dropout
Feature	Hydraulic Rebound-adjust Remote Lock-out, Air spring	Hydraulic Rebound-adjust Lock-out, Air spring	Hydraulic Rebound-adjust Remote Lock-out, Air spring	Hydraulic Rebound-adjust Remote Lock-out, Air spring	Hydraulic Rebound-adjust Remote Lock-out, Air spring	Hydraulic Rebound-adjust Remote Lock-out, Air spring	Hydraulic Rebound-adjust Remote Lock-out, Air spring	Hydraulic Rebound-adjust Remote Lock-out, Air spring	Hydraulic Rebound-adjust Remote Lock-out, Air spring	Hydraulic Rebound-adjust Remote Lock-out, Air spring	Hydraulic Rebound-adjust Remote Lock-out, Air spring	Hydraulic Rebound-adjust Remote Lock-out, Air spring
Damper	OCR C	OCR C	OCR C	OCR C	OCR C	OCR C	OCR C	OCR C	OCR	OCR	OCR	OCR
Spring	Air	Air	Air	Air	Air	Air	Air	Air	Air	Air	Air	Air
Adjustment	A,R,R,L,C	A,R,L,C	A,R,R,L,C	A,R,R,L,C	A,R,R,L,C	A,R,L,C	A,R,R,L,C	A,R,L,C	A,R,L,C	A,R,L,C	A,R,L,C	A,R,L,C
Travel	80, 100, 120 mm	80, 100, 120 mm	80, 100, 120 mm	80, 100, 120 mm	80, 100, 120 mm	80, 100, 120 mm	80, 100, 120 mm	80, 100, 120 mm	80, 100, 120 mm	80, 100, 120 mm	80, 100, 120 mm	80, 100, 120 mm
Fork offset	36mm	36mm	36mm	51mm	51mm	51mm	38mm	38mm	38mm	38mm	38mm	38mm
Fork height (mm)	460 / 480 / 500	460 / 480 / 500	460 / 480 / 500	490 / 510 / 530	490 / 510 / 530	490 / 510 / 530	460 / 480 / 500	460 / 480 / 500	460 / 480 / 500	460 / 480 / 500	460 / 480 / 500	460 / 480 / 500
Seal/Boot	spring seal	spring seal	spring seal	Spring Seal	Spring Seal	Spring Seal	spring seal	spring seal	spring seal	spring seal	spring seal	spring seal
Brake Type	Disc only	Disc only	Disc only	Disc only	Disc only	Disc only	Disc only	Disc only	Disc or D+V	Disc or D+V	Disc only	Disc only
Disc Brake Mount	Post	Post	Post	Post	Post	Post	Post	Post	Post	Post	Post	Post
Recommended Max. Rotor Size in mm	180	180	180	180	180	180	180	180	180	180	180	180
Dynamo Bracket Mount	—	—	—	—	—	—	—	—	—	—	—	—
Cable Guide for Hub Dynamo	—	—	—	—	—	—	—	—	—	—	—	—
Roller Brake Mount	—	—	—	—	—	—	—	—	—	—	—	—
Weight (kgs) (w/steerer at 200mm)	1.56	1.51	1.71	1.66	1.85	1.80	1.66	1.61	1.85	1.80	1.98	1.98
Wheel size	26"	26"	26"	26"	26"	26"	26"	26"	26"	26"	26"	26"
Origin of Production	Taiwan	Taiwan	Taiwan	Taiwan	Taiwan	Taiwan	Taiwan	Taiwan	Taiwan	Taiwan	Taiwan	Taiwan
2013 VS 2012	—	—	—	—	—	—	—	—	—	—	—	—
Remarks	—	—	—	—	—	—	—	—	—	—	—	—

Bike Category	XC		XC		JUNIOR		29er	
	FIRST 30-15	FIRST 30	FIRST 30	FIRST 30	FIRST 24	FIRST 28-15	FIRST 29	
Model	XC FIRST 30-15	XC FIRST 30	XC FIRST 30	XC FIRST 30	JUNIOR FIRST 24	JUNIOR FIRST 28-15	JUNIOR FIRST 29	
Model	Air	Platinum-SRL	Platinum	Air-SRL	Air	Air-SRL	Air	
Steerer	28.6mm 7050 Aluminum	28.6mm 7050 Aluminum	28.6mm 7050 Aluminum	28.6mm 7050 Aluminum	28.6mm 7050 Aluminum	28.6mm 7050 Aluminum	28.6mm 7050 Aluminum	
1.5" Steerer (Straight or Taper)	Option	Option	Option	Option	Option	Option	Option	
Crown	130mm Aluminum, Black Coating	130mm Aluminum, Black Coating	130mm Aluminum, Black Coating	130mm Aluminum, Black Coating	130mm Aluminum, Black Coating	130mm Aluminum, Black Coating	130mm Aluminum, Black Coating	
Stanchion	30mm	30mm	30mm	30mm	32mm	30mm	30mm	
Lower	7050 Aluminum Hard Anodize Magnesium 15mm QR	7050 Aluminum Hard Anodize Magnesium	7050 Aluminum Hard Anodize Magnesium	7050 Aluminum Hard Anodize Magnesium	7050 Aluminum Hard Anodize Magnesium 15mm QR	7050 Aluminum Hard Anodize Magnesium 15mm QR	7050 Aluminum Hard Anodize Magnesium 9mm Open Dropout	
Feature	Hydraulic Rebound-adjust Lock-out, Air spring	Hydraulic Rebound-adjust Lock-out, Air spring	Hydraulic Rebound-adjust Lock-out, Air spring	Hydraulic Rebound-adjust Lock-out, Air spring	Hydraulic Rebound-adjust Lock-out, Air spring	Hydraulic Rebound-adjust Lock-out, Air spring	Hydraulic Rebound-adjust Lock-out, Air spring	
Damper	OCR	OCR 2	OCR 2	OCR	OCR	OCR	OCR	
Spring	Air	Air	Air	Air	Air	Air	Air	
Adjustment	A,R,L,C	A,R,R,L,C	A,R,L,C	A,R,R,L,C	A,R,L,C	A,R,R,L,C	A,R,R,L,C	
Travel	80, 100, 120 mm	80, 100 mm	80, 100 mm	80, 100 mm	60 mm	80, 100, 120 mm	80, 100, 120 mm	
Fork offset	38mm	38mm	38mm	38mm	38mm	51mm	51mm	
Fork height (mm)	460 / 480 / 500	460 / 480	460 / 480	460 / 480	410	490 / 510 / 530	490 / 510 / 530	
Seal/Boot	Spring Seal	Spring Seal	Spring Seal	Spring Seal	Spring Seal	Spring Seal	Spring Seal	
Brake Type	Disc Only	Disc or D+V	Disc or D+V	Disc or D+V	D+V	Disc Only	Disc Only	
Disc Brake Mount	Post	Post	Post	Post	Post	Post	Post	
Recommended Max. Rotor Size in mm	180	180	180	180	180	180	180	
Dynamo Bracket Mount	—	—	—	—	—	—	—	
Cable Guide for Hub Dynamo	—	—	—	—	—	—	—	
Roller Brake Mount	—	—	—	—	—	—	—	
Weight (kgs) (w/steerer at 200mm)	1.93	1.55	1.50	1.80	1.75	1.60	1.99	
Wheel size	26"	26"	26"	26"	24"	29"	29"	
Origin of Production	Taiwan	Taiwan	Taiwan	Taiwan	Taiwan	Taiwan	Taiwan	
2013 VS 2012	—	—	—	—	—	—	—	
Remarks								

Bike Category	XC		XC		29er		29er	
	AERIAL 32	AERIAL 30	AERIAL 30	AERIAL 30	AERIAL 30	OMAGE 29	OMAGE 29	
Model	RL	TNL	ML	RL	TNL	ML	TNL	
Steerer	28.6mm Steel	28.6mm Steel	28.6mm Steel	28.6mm Steel	28.6mm Steel	28.6mm Steel	28.6mm Steel	
1.5" Steerer (Straight or Taper)	Option	Option	Option	Option	Option	Option	Option	
Crown	130mm Aluminum, Black Coating	130mm Aluminum, Black Coating	130mm Aluminum, Black Coating	130mm Aluminum, Black Coating	130mm Aluminum, Black Coating	130mm Aluminum, Black Coating	130mm Aluminum, Black Coating	
Stanchion	32mm Steel Ti color	32mm Steel Ti color	30mm Steel Ti color	30mm Steel Ti color	32mm Steel Ti color	32mm Steel Ti color	32mm Steel Ti color	
Lower	9mm Open Dropout	9mm Open Dropout	9mm Open Dropout	9mm Open Dropout	9mm Open Dropout	9mm Open Dropout	9mm Open Dropout	
Feature	Hydraulic RemoteLock-out, Air spring	Hydraulic Lock-out, Air spring	Hydraulic Lock-out, Air spring	Hydraulic RemoteLock-out, Air spring	Hydraulic Lock-out, Air spring	Mechanical Lock-out, Air spring	Hydraulic Lock-out	
Damper	Hydraulic Cartridge	Hydraulic Cartridge	Hydraulic Cartridge	Hydraulic Cartridge	Hydraulic Cartridge	Hydraulic Cartridge	Hydraulic Cartridge	
Spring	Air	Air	Air	Air	Air	Air	Coil	
Adjustment	A,RL	A,L	A,L	A,RL	A,L	A,L	RL,P (easy preload)	
Travel	80, 100, 120 mm	80, 100, 120 mm	80, 100, 120 mm	80, 100, 120 mm	80, 100, 120 mm	80, 100, 120 mm	80, 100, 120 mm	
Fork offset	38mm	38mm	38mm	38mm	38mm	51mm	51mm	
Fork height (mm)	460 / 480 / 500	460 / 480 / 500	460 / 480 / 500	460 / 480 / 500	490 / 510 / 530	490 / 510 / 530	490 / 510 / 530	
Seal/Boot	Spring Seal	Spring Seal	Spring Seal	Spring Seal	Spring Seal	Spring Seal	Spring Seal	
Brake Type	Disc or D+V	Disc or D+V	Disc or D+V	Disc or D+V	Disc or Only	Disc Only	Disc Only	
Disc Brake Mount	Post	Post	Post	Post	Post	Post	Post	
Recommended Max. Rotor Size in mm	180	180	180	180	180	180	180	
Dynamo Bracket Mount	—	—	—	—	—	—	—	
Cable Guide for Hub Dynamo	—	—	—	—	—	—	—	
Roller Brake Mount	—	—	—	—	—	—	—	
Weight (kgs) (w/steerer at 200mm)	2.45	2.37	2.14	2.34	2.27	2.48	2.55	
Wheel size	26"	26"	26"	26"	26"	29"	29er	
Origin of Production	Taiwan	Taiwan	Taiwan	Taiwan	Taiwan	Taiwan	China	
2013 VS 2012	New	New	New	New	New	New	New	
Remarks								

Bike Category	29er				XC				29er				XC/ SPORT		
	OMEGA 29				OMEGA				BLAZE 29				BLAZE		
Model	ML	T	RL	TNL	ML	T	RL	TNL	ML	T	RL	TNL	ML	T	RL
Steerer	28.6mm Steel	28.6mm Steel	28.6mm Steel	28.6mm Steel	28.6mm Steel	28.6mm Steel	28.6mm Steel	28.6mm Steel	28.6mm Steel	28.6mm Steel	28.6mm Steel	28.6mm Steel	28.6mm Steel	28.6mm Steel	28.6mm Steel
1.5" Steerer (Straight or Taper)	-	-	-	-	-	-	-	-	-	-	-	-	-	-	-
Crown	130mm Aluminum, ED Black	130mm Aluminum, ED Black	130mm Aluminum, ED Black	130mm Aluminum, ED Black	130mm Aluminum, ED Black	130mm Aluminum, ED Black	130mm Aluminum, ED Black	130mm Aluminum, ED Black	130mm Aluminum, ED Black	130mm Aluminum, ED Black	130mm Aluminum, ED Black	130mm Aluminum, ED Black	130mm Aluminum, ED Black	130mm Aluminum, ED Black	130mm Aluminum, ED Black
Stanchion	32mm Steel	32mm Steel	30mm Steel	30mm Steel	30mm Steel	30mm Steel	30mm Steel	30mm Steel	30mm Steel	30mm Steel	30mm Steel	30mm Steel	30mm Steel	30mm Steel	30mm Steel
Lower	Magnesium 9mm Open Dropout	Magnesium 9mm Open Dropout	Magnesium 9mm Open Dropout	Magnesium 9mm Open Dropout	Magnesium 9mm Open Dropout	Magnesium 9mm Open Dropout	Magnesium 9mm Open Dropout	Magnesium 9mm Open Dropout	Magnesium 9mm Open Dropout	Magnesium 9mm Open Dropout	Magnesium 9mm Open Dropout	Magnesium 9mm Open Dropout	Magnesium 9mm Open Dropout	Magnesium 9mm Open Dropout	Magnesium 9mm Open Dropout
Feature	Mechanical Lock-out	-	Hydraulic Lock-out	Hydraulic Lock-out	Mechanical Lock-out	-	Hydraulic Remote Lock-out	Hydraulic Lock-out	Mechanical Lock-out	-	Hydraulic Remote Lock-out	Hydraulic Lock-out	Mechanical Lock-out	-	Hydraulic Remote Lock-out
Damper	-	-	Hydraulic Cartridge	Hydraulic Cartridge	-	-	Hydraulic Cartridge	Hydraulic Cartridge	-	-	Hydraulic Cartridge	Hydraulic Cartridge	-	-	Hydraulic Cartridge
Spring	Coil	Coil	Coil	Coil	Coil	Coil	Coil	Coil	Coil	Coil	Coil	Coil	Coil	Coil	Coil
Adjustment	L,P (easy preload)	P (easy preload)	RL,P (easy preload)	L,P (easy preload)	L,P (easy preload)	P (easy preload)	RL,P (easy preload)	L,P (easy preload)	L,P (easy preload)	P (easy preload)	RL,P (easy preload)	L,P (easy preload)	L,P (easy preload)	P (easy preload)	RL,P (easy preload)
Travel	80, 100, 120 mm	80, 100, 120 mm	80, 100, 120 mm	80, 100, 120 mm	80, 100, 120 mm	80, 100, 120 mm	80, 100, 120 mm	80, 100, 120 mm	80, 100, 120 mm	80, 100, 120 mm	80, 100, 120 mm	80, 100, 120 mm	80, 100, 120 mm	80, 100, 120 mm	80, 100, 120 mm
Fork offset	51mm	51mm	38mm	38mm	38mm	38mm	38mm	38mm	38mm	38mm	38mm	38mm	38mm	38mm	38mm
Fork height (mm)	490 / 510	490 / 510	460 / 480 / 500	460 / 480 / 500	460 / 480 / 500	460 / 480 / 500	460 / 480 / 500	460 / 480 / 500	460 / 480 / 500	460 / 480 / 500	460 / 480 / 500	460 / 480 / 500	460 / 480 / 500	460 / 480 / 500	460 / 480 / 500
Seal/Boot	Spring Seal	Spring Seal	Spring Seal	Spring Seal	Spring Seal	Spring Seal	Spring Seal	Spring Seal	Spring Seal	Spring Seal	Spring Seal	Spring Seal	Spring Seal	Spring Seal	Spring Seal
Brake Type	Disc Only	Disc Only	Disc or D+V	Disc or D+V	Disc or D+V	Disc or D+V	Disc or D+V	Disc or D+V	Disc or D+V	Disc or D+V	Disc or D+V	Disc or D+V	Disc or D+V	Disc or D+V	Disc or D+V
Disc Brake Mount Recommended Max. Rotor Size in mm	Post	Post	Post	Post	Post	Post	Post	Post	Post	Post	Post	Post	Post	Post	Post
Dynamo Bracket Mount Cable Guide for Hub Dynamo	180	180	180	180	180	180	180	180	180	180	180	180	180	180	180
Roller Brake Mount Weight (kgs) (w/steerer at 200mm)	-	-	-	-	-	-	-	-	-	-	-	-	-	-	-
Wheel size	2.24	2.24	2.44	2.37	2.11	2.11	2.92	2.84	2.61	2.63	2.62	2.62	2.62	2.62	2.62
Origin of Production	China	China	China	China	China	China	China	China	China	China	China	China	China	China	China
2013 VS 2012	-	New	-	-	-	New	-	-	-	-	-	-	-	-	-
Remarks	-	-	-	-	-	-	-	-	-	-	-	-	-	-	-

RST 2013 PRODUCT SPECIFICATION

Bike Category	XC/ SPORT				650B				XC/ SPORT						
	BLAZE				BLAZE 650B				GILA						
Model	TNL	ML	T	RL	TNL	ML	T	RL	TNL	ML	T	RL	TNL	ML	T
Steerer	28.6mm Steel	28.6mm Steel	28.6mm Steel	28.6mm Steel	28.6mm Steel	28.6mm Steel	28.6mm Steel	28.6mm Steel	28.6mm Steel	28.6mm Steel	28.6mm Steel	28.6mm Steel	28.6mm Steel	28.6mm Steel	28.6mm Steel
1.5" Steerer (Straight or Taper)	-	-	-	-	-	-	-	-	-	-	-	-	-	-	-
Crown	130mm Aluminum, ED Black	130mm Aluminum, ED Black	130mm Aluminum, ED Black	130mm Aluminum, ED Black	130mm Aluminum, ED Black	130mm Aluminum, ED Black	130mm Aluminum, ED Black	130mm Aluminum, ED Black	130mm Aluminum, ED Black	130mm Aluminum, ED Black	130mm Aluminum, ED Black	130mm Aluminum, ED Black	130mm Aluminum, ED Black	130mm Aluminum, ED Black	130mm Aluminum, ED Black
Stanchion	30mm Steel	30mm Steel	30mm Steel	30mm Steel	30mm Steel	30mm Steel	30mm Steel	30mm Steel	30mm Steel	30mm Steel	30mm Steel	30mm Steel	30mm Steel	30mm Steel	30mm Steel
Lower	Aluminum 9mm Open Dropout	Aluminum 9mm Open Dropout	Aluminum 9mm Open Dropout	Aluminum 9mm Open Dropout	Aluminum 9mm Open Dropout	Aluminum 9mm Open Dropout	Aluminum 9mm Open Dropout	Aluminum 9mm Open Dropout	Aluminum 9mm Open Dropout	Aluminum 9mm Open Dropout	Aluminum 9mm Open Dropout	Aluminum 9mm Open Dropout	Aluminum 9mm Open Dropout	Aluminum 9mm Open Dropout	Aluminum 9mm Open Dropout
Feature	Hydraulic Lock-out	Mechanical Lock-out	-	Hydraulic Remote Lock-out	Mechanical Lock-out	Mechanical Lock-out	-	Hydraulic Remote Lock-out	Mechanical Lock-out	Mechanical Lock-out	Mechanical Lock-out	Hydraulic Remote Lock-out	Mechanical Lock-out	Mechanical Lock-out	Mechanical Lock-out
Damper	Hydraulic Cartridge	-	-	Hydraulic Cartridge	Hydraulic Cartridge	-	-	Hydraulic Cartridge	Hydraulic Cartridge	-	-	Hydraulic Cartridge	Hydraulic Cartridge	-	-
Spring	Coil	Coil	Coil	Coil	Coil	Coil	Coil	Coil	Coil	Coil	Coil	Coil	Coil	Coil	Coil
Adjustment	L,P	L,P	P	RL,P	L,P	L,P	P	RL,P	L,P	L,P	P	RL,P	L,P	L,P	P
Travel	80, 100, 120 mm	80, 100, 120 mm	80, 100, 120 mm	80, 100, 120 mm	80, 100, 120 mm	80, 100, 120 mm	80, 100, 120 mm	80, 100, 120 mm	80, 100, 120 mm	80, 100, 120 mm	80, 100, 120 mm	80, 100, 120 mm	80, 100, 120 mm	80, 100, 120 mm	80, 100, 120 mm
Fork offset	38mm	38mm	38mm	38mm	38mm	38mm	38mm	38mm	38mm	38mm	38mm	38mm	38mm	38mm	38mm
Fork height (mm)	460 / 480 / 500	460 / 480 / 500	460 / 480 / 500	460 / 480 / 500	460 / 480 / 500	460 / 480 / 500	460 / 480 / 500	460 / 480 / 500	460 / 480 / 500	460 / 480 / 500	460 / 480 / 500	460 / 480 / 500	460 / 480 / 500	460 / 480 / 500	460 / 480 / 500
Seal/Boot	Spring Seal	Spring Seal	Spring Seal	Spring Seal	Spring Seal	Spring Seal	Spring Seal	Spring Seal	Spring Seal	Spring Seal	Spring Seal	Spring Seal	Spring Seal	Spring Seal	Spring Seal
Brake Type	Disc or D+V	Disc or D+V	Disc or D+V	Disc or D+V	Disc or D+V	Disc or D+V	Disc or D+V	Disc or D+V	Disc or D+V	Disc or D+V	Disc or D+V	Disc or D+V	Disc or D+V	Disc or D+V	Disc or D+V
Disc Brake Mount Recommended Max. Rotor Size in mm	Post	Post	Post	Post	Post	Post	Post	Post	Post	Post	Post	Post	Post	Post	Post
Dynamo Bracket Mount Cable Guide for Hub Dynamo	180	180	180	180	180	180	180	180	180	180	180	180	180	180	180
Roller Brake Mount Weight (kgs) (w/steerer at 200mm)	-	-	-	-	-	-	-	-	-	-	-	-	-	-	-
Wheel size	2.55	2.30	2.34	2.83	2.76	2.51	2.55	2.42	2.35	2.10	2.05	2.05	2.05	2.05	2.05
Origin of Production	China	China	China	China	China	China	China	China	China	China	China	China	China	China	China
2013 VS 2012	-	-	-	New	New	New	New	New	New	New	New	New	New	New	New
Remarks	-	-	-	-	-	-	-	-	-	-	-	-	-	-	-

Bike Category	SPORT		DIRT JUMP			DIRT JUMP			CROSS			
	CAPA	T26,T24,T20	SPACE	FREE	RA	T	Air-SRL	Air	RL	TNL	VITA	T
Model	ML26,24	28.6mm /25.4mm Steel	28.6mm Aluminum	28.6mm Cr-mo steel	28.6mm steel	28.6mm steel	28.6mm 7050 Aluminum	28.6mm 7050 Aluminum	28.6 / 25.4mm steel	28.6 / 25.4mm steel	28.6 / 25.4mm steel	28.6 / 25.4mm steel
Steerer (Straight or Taper)	—	—	—	—	—	—	—	—	—	—	—	—
Crown	120mm Aluminum ED Black	120mm Aluminum ED Black	138mm Aluminum, Black Coating	138mm Aluminum, Black Coating	130mm Aluminum, ED Black	130mm Aluminum, ED Black	112mm Aluminum, Black Coating	112mm Aluminum, Black Coating	112mm Aluminum, ED Black	112mm Aluminum, ED Black	112mm Aluminum, ED Black	112mm Aluminum, ED Black
Stanchion	25.4mm Steel CP	25.4mm Steel CP	36mm 7050 Aluminum Anodize	36mm 7050 Aluminum Ti color	32 steel CP	32 steel CP	28.6mm 7050 Aluminum Hard Anodize	28.6mm 7050 Aluminum Hard Anodize	28.6mm Steel Ti color	28.6mm Steel Ti color	28.6mm Steel Ti color	28.6mm Steel Ti color
Lower	Aluminum 9mm Open Dropout	Aluminum 9mm Open Dropout	Magnesium 20mm Convertible	Magnesium 20mm Convertible	Aluminum 9mm Open Dropout	Aluminum 9mm Open Dropout	Magnesium 9mm Open Dropout	Magnesium 9mm Open Dropout	Magnesium 9mm Open Dropout	Magnesium 9mm Open Dropout	Magnesium 9mm Open Dropout	Magnesium 9mm Open Dropout
Feature	Hydraulic Lock-out	—	Hydraulic Rebound-adjust, Air spring	Hydraulic Rebound-adjust	Hydraulic Rebound-adjust	Hydraulic Rebound-adjust	Hydraulic Rebound-adjust Remote Lock-out, Air spring	Hydraulic Rebound-adjust Lock-out, Air spring	Hydraulic Remote Lock-out	Hydraulic Lock-out	Mechanical Lock-out	—
Damper	—	Hydraulic Cartridge	Hydraulic Cartridge	Hydraulic Cartridge	Hydraulic Cartridge	Hydraulic Cartridge	OCR	OCR	Hydraulic Cartridge	Hydraulic Cartridge	—	—
Spring	Coil	Coil	Air	Coil	Coil	Coil	Air	Air	Coil	Coil	Coil	Coil
Adjustment	L,P	P	A,R	R	R,P	P	A,R,R,L,C	A,R,L,C	R,L,P (easy preload)	L,P (easy preload)	L,P (easy preload)	P (easy preload)
Travel	26"/24" : 80/50 mm	26"/24"/20"/80/50/50 mm	80, 100 mm	80, 100 mm	80, 100, 130 mm	80, 100, 130 mm	50, 60, 75 mm	50, 60, 75 mm	50, 60 mm	50, 60 mm	50, 60 mm	50, 60 mm
Fork offset	38mm	38mm	38mm	38mm	38mm	38mm	44mm	44mm	46mm	46mm	46mm	46mm
Fork height (mm)	26"/24" : 460 / 399	26"/24"/20"/460/399/373	465 / 485	465 / 485	460 / 480 / 510	460 / 480 / 510	460 / 470 / 485	460 / 470 / 485	460 / 470	460 / 470	460 / 470	460 / 470
Seal/Boot	Spring Seal	Spring Seal	Spring Seal	Spring Seal	Spring Seal	Spring Seal	Spring Seal	Spring Seal	Spring Seal	Spring Seal	Spring Seal	Spring Seal
Brake Type	D+V	D+V	Disc Only	Disc Only	Disc or D+V	Disc or D+V	Disc or D+V	Disc or D+V	Disc or D+V	Disc or D+V	Disc or D+V	Disc or D+V
Disc Brake Mount Recommended Max. Rotor Size in mm	IS	IS	IS	IS	Post	Post	IS	IS	IS	IS	IS	IS
Dynamo Bracket Mount Cable Guide for Hub Dynamo	180	180	203	203	180	180	180	180	180	180	180	180
Roller Brake Mount Weight (kgs) (w/steerer at 200mm)	2.03 / 1.93	1.98/1.84/1.75	2.63	2.93	3.01	3.05	1.68	1.63	2.28	2.20	1.98	1.98
Wheel size	26"/24"	Available for 26"/24"/20"	26"	26"	26"	26"	700C Only	700C Only	700C Only	700C Only	700C Only	700C Only
Origin of Production	China	China	Taiwan	Taiwan	China	China	Taiwan	Taiwan	China	China	China	China
2013 VS 2012	—	—	—	—	—	—	—	—	—	—	—	—
Remarks	—	—	—	—	—	—	—	—	—	—	—	—

130mm travel only available with special reinforced steerer tube

Bike Category	CROSS			TREKKING / CITY		
	NEON-PLS (Post Lighting System)	NEON	SOFI PLS (Post Light System)	NEON	TREKKING / CITY	SOFI
Model	RL	ML	T	RL	T	ML
Steerer	28.6/25.4mm Steel	28.6/25.4mm Steel	28.6/25.4mm Steel	28.6/25.4mm Steel	28.6/25.4mm Steel	28.6/25.4mm Steel
1.5" Steerer (Straight or Taper)	—	—	—	—	—	—
Crown	112mm Aluminum, ED Black	112mm Aluminum, ED Black	112mm Aluminum, ED Black	112mm Aluminum, ED Black	112mm Aluminum, ED Black	112mm Aluminum, ED Black
Stanchion	28.6mm Steel CP	25.4mm Steel CP	28.6mm Steel CP	25.4mm Steel CP	25.4mm Steel CP	25.4mm Steel CP
Lower	Aluminum 9mm Open Dropout	Aluminum 9mm Open Dropout	Aluminum 9mm Open Dropout	Aluminum 9mm Open Dropout	Aluminum 9mm Open Dropout	Aluminum 9mm Open Dropout
Feature	Hydraulic Remote Lock-out	Hydraulic Remote Lock-out	Hydraulic Remote Lock-out	Hydraulic Remote Lock-out	Hydraulic Remote Lock-out	Mechanical Lock-out
Damper	Hydraulic Cartridge	Hydraulic Cartridge	Hydraulic Cartridge	Hydraulic Cartridge	Hydraulic Cartridge	Hydraulic Cartridge
Spring	Coil	Coil	Coil	Coil	Coil	Coil
Adjustment	RL,P	L,P	P	RL,P	P	L,P
Travel	50, 60 mm	700C:50, 60 mm	26":75 mm	40, 50 mm	700C:40, 50 mm	26":50 mm
Fork offset	44mm	26":38mm / 700C:44mm	44mm	44mm	26":38mm / 700C:44mm	26":50 mm
Fork height (mm)	460 / 470	700C:460 / 470 ,	26":465	450 / 460	700C:450 / 460 ,	26":450
Seal/Boot	Spring Seal	Spring Seal	Spring Seal	Spring Seal	Spring Seal	Spring Seal
Brake Type	Disc or D+V	D+V	D+V	V-break Only	V-break Only	V-break Only
Disc Brake Mount Recommended Max. Rotor Size in mm	IS	IS	IS	no	no	no
Dynamo Bracket Mount Cable Guide for Hub Dynamo	180	180	180	NIL	NIL	NIL
Roller Brake Mount Weight (kgs) (w/steerer at 200mm)	2.59	2.30	2.31	2.59	2.30	2.06
Wheel size	Available for 700C	Available for 700C &26"	Available for 700C &26"	Available for 700C	Available for 700C &26"	Available for 700C &26"
Origin of Production	China	China	China	China	China	China
2013 VS 2012	—	—	—	—	—	—
Remarks	—	—	—	—	—	—

Bike Category	TREKKING / CITY			HYDRO FORMING			SINGLE SHOCK		
	SOFI	HYDRO-7	HYDRO-6	HYDRO-R	SS-HF7	SS-HF6	SS-M7-T	SS-M6-T	SS-M6
Model									
Steerer	28.6/25.4mm Steel	28.6mm A-7050 Aluminum	28.6mm A-7050 Aluminum	28.6mm A-7050 Aluminum	28.6mm A-7050 Aluminum	28.6mm A-7050 Aluminum	28.6mm 7050 Aluminum (200mm length min.)	28.6mm 7050 Aluminum (200mm length min.)	28.6mm 7050 Aluminum (200mm length min.)
1.5" Steerer (Straight or Taper)	-	-	-	-	-	-	-	-	-
Crown	112mm Aluminum, ED Black	-	-	-	-	-	-	-	-
Stanchion	28.6mm Steel CP	-	-	-	-	-	-	-	-
Lower	Aluminum 9mm Open Dropout	Aluminum 9mm Open Dropout	Aluminum 9mm Open Dropout	Aluminum 9mm Open Dropout	Aluminum 9mm Open Dropout	Aluminum 9mm Open Dropout	Magnesium 9mm Open Dropout	Magnesium 9mm Open Dropout	Magnesium 9mm Open Dropout
Feature	-	Alu. blade	Alu. blade	Alu. blade	Alu. blade	Alu. blade	Mag. blade (Spring preload)	Mag. blade (Spring preload)	Mag. blade
Damper	-	-	-	-	-	-	-	-	-
Spring	Coil	-	-	-	-	-	Coil with bumper	Coil with bumper	Coil with bumper
Adjustment	P	-	-	-	-	-	P	P	-
Travel	700C:40, 50 mm 26":50 mm	-	-	-	35mm	35mm	35mm	35mm	35mm
Fork offset	26":38mm 700C:44mm	43	38	38	43	43	43	43	43
Fork height (mm)	700C:450 / 460 26":450	408	373	372.4	455	435	475	440	435
Seal/Boot	Spring Seal	-	-	-	long boot	long boot	long boot	long boot	long boot
Brake Type	V-brake Only	OPTION(V-brake, Disc brake)	Caliper-brake	Disc & V-brake	OPTION(V-brake, Disc brake)	OPTION(V-brake, Disc brake)	OPTION(V-brake, Disc brake)	OPTION(V-brake, Disc brake)	OPTION(V-brake, Disc brake)
Disc Brake Mount	no	IS	IS	IS	IS	IS	IS	IS	IS
Recommended Max. Rotor Size in mm	NIL	-	-	180	180	160	160	160	160
Dynamo Bracket Mount	yes	-	-	-	-	-	yes	yes	yes
Cable Guide for Hub Dynamo	option	-	-	-	-	-	yes	yes	yes
Roller Brake Mount	no	-	-	-	-	-	option	option	option
Weight (kgs) (w/steerer at 200mm)	2.07	0.65	0.60	0.55	1.15	1.10	1.33	1.18	1.18
Wheel size	Available for 700C & 26"	700C	26"	700C	700C	26"	700C	26"	26"
Origin of Production	China	Taiwan	Taiwan	Taiwan	Taiwan	Taiwan	Taiwan	Taiwan	Taiwan
2013 VS 2012	-	New	New	New	New	New	-	-	-
Remarks									

Bike Category	SINGLE SHOCK			RIGID FORK						
	SS-A7-T	SS-A7	SS-A6-T	SS-A6	SS-A4-T	SS-A4	SS-A2-75	SS-A2-100	RF-M7	RF-M6
Model										
Steerer	28.6mm 7050 Aluminum (200mm length min.)	28.6mm 7050 Aluminum (200mm length min.)	28.6mm 7050 Aluminum (200mm length min.)	28.6mm 7050 Aluminum (200mm length min.)	28.6mm 7050 Aluminum (200mm length min.)	28.6mm 7050 Aluminum (200mm length min.)	28.6mm 7050 Aluminum (200mm length min.)	28.6mm 7050 Aluminum (200mm length min.)	28.6mm 7050 Aluminum	28.6mm 7051 Aluminum
1.5" Steerer (Straight or Taper)	-	-	-	-	-	-	-	-	-	-
Crown	-	-	-	-	-	-	-	-	-	-
Stanchion	-	-	-	-	-	-	-	-	-	-
Lower	Aluminum 9mm Open Dropout	Aluminum 9mm Open Dropout	Aluminum 9mm Open Dropout	Aluminum 9mm Open Dropout	Aluminum 9mm Open Dropout	Aluminum 9mm Open Dropout	Aluminum 9mm Open Dropout	Aluminum 9mm Open Dropout	Magnesium 9mm Open Dropout	Magnesium 9mm Open Dropout
Feature	Alu. Blade Spring preload	Alu. blade	Alu. Blade Spring preload	Alu. blade	Alu. Blade Spring preload	Alu. blade	Alu. Blade (straight) Dropout pitch 100mm	Alu. Blade (straight) Dropout pitch 75mm	Mag. Blade	Mag. Blade
Damper	-	-	-	-	-	-	-	-	-	-
Spring	Coil with bumper	Coil with bumper	Coil with bumper	Coil with bumper	Coil with bumper	Coil with bumper	Coil with bumper	Coil with bumper	-	-
Adjustment	P	-	P	-	P	-	-	-	-	-
Travel	30mm	35mm	30mm	35mm	30mm	30mm	30mm	30mm	-	-
Fork offset	43	43	43	415	405	405	34	34	-	-
Fork height (mm)	460	455	440	435	405	405	345	345	408	373
Seal/Boot	long boot	long boot	long boot	long boot	long boot	long boot	long boot	long boot	-	-
Brake Type	Disc & V-brake (Disc only)(Optional Roller Mount)	Disc & V-brake	Disc & V-brake	Disc & V-brake	Disc & V-brake	Disc & V-brake	V-brake	Disc & V-brake (Optional Roller Mount)	-	-
Disc Brake Mount	IS	IS	IS	IS	IS	IS	IS	IS	IS	IS
Recommended Max. Rotor Size in mm	180	180	180	180	160	160	-	160	160	160
Dynamo Bracket Mount	yes	yes	yes	yes	yes	yes	-	-	yes	yes
Cable Guide for Hub Dynamo	yes	yes	yes	yes	yes	yes	-	-	yes	yes
Roller Brake Mount	option	option	option	option	-	-	-	-	yes	yes
Weight (kgs) (w/steerer at 200mm)	1.60	1.60	1.52	1.52	1.51	1.45	1.28	1.32	0.83	0.75
Wheel size	700C	700C	26"	26"	24"	24"	20"	20"	700C	26"
Origin of Production	Taiwan	Taiwan	Taiwan	Taiwan	Taiwan	Taiwan	Taiwan	Taiwan	Taiwan	Taiwan
2013 VS 2012	-	-	-	-	-	-	-	-	-	-
Remarks										

GLOBAL OVERVIEW

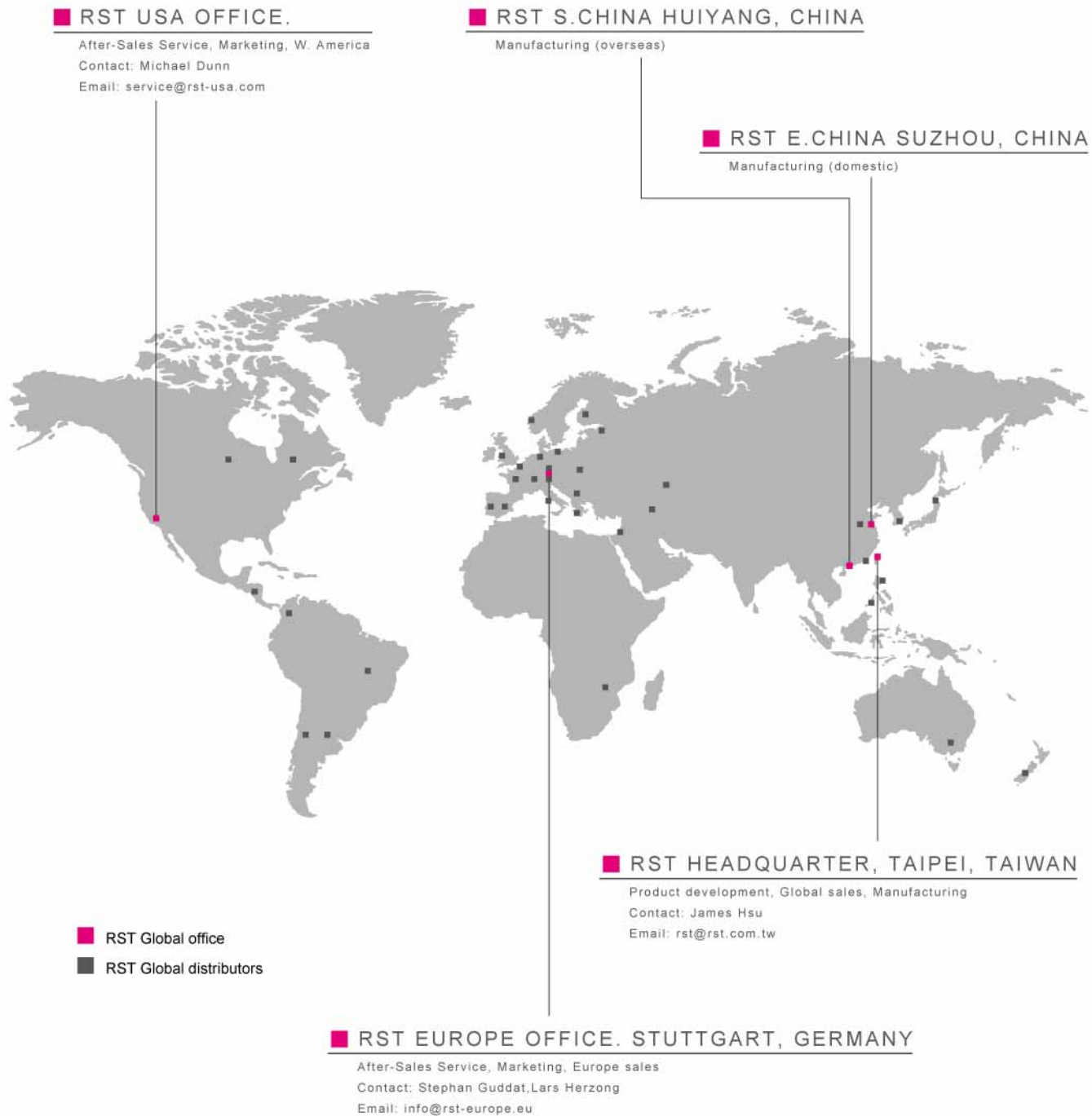

GLOBAL DISTRIBUTOR



ARGENTINA

Carlos Karabitan
Tel : 54-351-4936060
Fax: 54-351-4931003
carlos@karabitan.com.ar

AUSTRIA

Thalinger Lange GMBH
Tel : 43-7242-497260
Fax: 43-7242-497401
mail@thalinger-lange.com

AUSTRALIA

Avanti Bicycle Co., Ltd.
Tel : 03-9586-8300
Fax: 03-9586-8301
nzqquiries@avantibikes.com

BRAZIL

LM BIKE
Tel : 55-37-3262-5100
faleconosco@lmbike.com.br

BENELUX

Cyclia bv
Tel : 31-(0)20-6692936
Fax: 31-(0)20-6154589
info@cyclia.nl

CHILE

Droppelmann Limitade
Tel : 56-2-695-0776
Fax: 56-2-556-5678
ventas@tdropp.cl

COLOMBIA

Len Importaciones
Tel : 57-7-671-2222
marcela@lenimp.com

COSTA RICA

DISTRIBUIDORA 86 S.R.L.
TEL : 506-445-6669
FAX : 506-445-6185
info@superpro.ws

CZECH/SLOVAK REPUBLIC

Universe Agency spol. s.r.o.
Tel : 420-2-2491-9143
Fax: 420-2-2491-8139
info@uniag.cz

CANADA

D'amour Bicycle & Sport, Inc
Tel : 1-514-637-6511
Fax: 1-514-637-7999
damco@damourbicycle.com

CHINA

Suzhou Top way Precision Co., Ltd.
Tel : 86-512-88855658
Fax: 86-512-88855658
www.rstlife.com service@rst-topway.cn

ESTONIA

Velo Plus.
Tel : 372-6-555-577
Fax: 372-6-556-308
info@veloplus.ee

FRANCE

RST-Paul Lange France SARL
Tel : 03-88-932101
Fax: 03-88-933432
julien.prevot@paul-lange.fr

GERMANY

Paul Lange & Co.
Tel : 49-711-258802
Fax: 49-711-2588305
info@paul-lange.de

GREECE

Nikos Maniopoulos S.A.
Tel : 30-2610-993045
Fax: 30-2610-990424
amarket@idealbikes.gr

HUNGARY

VELOBIKE Kft.
Tel: 36-1-455-8010
Fax: 36-1-455-8019

INDONESIA

Ban Cong Hien
Tel : 62-31-3538686
Fax: 62-31-3537117
waspada_68@yahoo.com

ISRAEL

Ranofun
Tel : 97-2545-600212
Fax: 972-8-9200061
ranofun@gmail.com

ITALY

Ciclo Promo Components SPA
Tel : 39-0423-1996363
Fax: 39-0423-1996364
info@ciclopromo.com

JAPAN

AKI Corporation, Ltd.
Tel : 81-72-887-5515
Fax: 81-72-887-5517
info@akiworld.co.jp

KOREA

MBS Corporation
Tel: 82-55-265-9415
Fax: 82-55-265-9419
elfama@elfama.com

NEW ZEALAND

Sheppard Industries, Ltd.
Tel : 64-9-915-5770
Fax: 64-9-915-5902
office@sheppardind.co.nz

NORWAY

Deler A/S
Tel : 47-6498-9950
Fax: 47-6498-9968
support@deler.no

PHILIPPINES

YKK Trading
Tel: 6332-255-8853
Fax: 6332-253-8489
info@ykkbikes.com

POLAND

Velo Sp. Z. O. O.
Tel : 48-32-232-83-77
Fax: 48-32-232-83-80
office@velo.pl

PORTUGAL

Motokit
Tel: 351-234-625607
Fax: 351-234-625608
mail@motokit.com.pt

RUSSIA

Velomotors Co., Ltd.
Tel : +7-095-559-0200
Fax: +7-095-559-1458

SWITZERLAND

Fuchs-movesa AG
Tel : 62-865-66-06
Fax: 62-865-66-09
info@fuchs-movesa.ch

SLOVENIA/CROATIA

CS-EUROTRADE d.o.o.
Tel : 386-7-49-02-500
Fax: 386-7-49-02-549
info@cs-eurotrade.com

THAILAND

Asia International Business & Sales Co., Ltd.
Tel : 66-2-887-7813-4
Tel : 66-2-448-3150
seema1@ksc.th.com

TAIWAN

Chyuan Hong Yi Enterprise Co., Ltd.
Tel : 886-4-2626-7719
Fax: 886-4-2628-0751

U.K.

The SILO
Tel : +44 (0)1288 331180
Fax: +44 (0)1288 331181

U.S.A.

Quality Bicycle Products
Tel : 1-800-346-0004
Fax: 1-800-346-0211
sales@qbp.com

VENEZUELA

Industrias Metalkia, C.A.
Tel : 58-212-3712460
Fax: 58-212-3735980
metalkia@cantv.net